

**Model T-C1**  
**(Machine Code: B174)**  
**SERVICE MANUAL**

5 March 2004  
Subject to Change

# PRECAUTIONS

The cautions in the below are items needed to keep in mind when maintaining and servicing.

Please read carefully and keep the contents in mind to prevent accidents while servicing and to prevent that the machine gets damage.

## WARNING FOR SAFETY

### 1. Request the service by qualified service person.

The service for this machine must be performed by a service person who took the additional education of this field. It is dangerous if unqualified service person or user tries to fix the machine.

### 2. Do not rebuild it discretionary.

Do not attach or change parts discretionary. Do not disassemble, fix, and rebuilt it. If you do, the printer will not work and electric shock or a fire can occur.

### 3. Laser Safety Statement

The Printer is certified in the U.S. to conform to the requirements of DHHS 21 CFR, chapter 1 Subchapter J for Class 1(1) laser products, and elsewhere, it is certified as a Class I laser product conforming to the requirements of IEC 825. Class I laser products are not considered to be hazardous. The laser system and printer are designed so there is never any human access to laser radiation above a Class I level during normal operation, user maintenance, or prescribed service condition.

## WARNING

**Never operate or service the printer with the protective cover removed from Laser/Scanner assembly. The reflected beam, although invisible, can damage your eyes. When using this product, these basic safety precautions should always be followed to reduce risk of fire, electric shock, and injury to persons.**

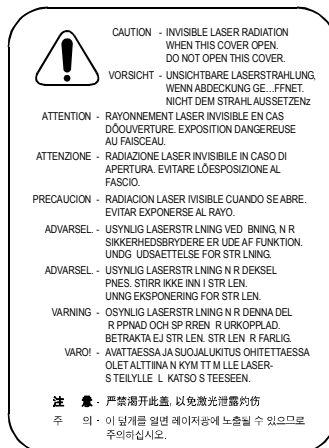

CAUTION.WMF

## **CAUTION FOR SAFETY**



### **PRECAUTION RELATED NOXIOUS MATERIAL**

It is possible to get harmed from noxious material if you ignore the below information.

1. Do not touch the damaged LCD. This PRINTER has LCD in control panel. Noxious liquid to human body exists in the LCD. If it is got into mouth, immediately see a doctor. If it is got into eyes or on skin, immediately wash off over 15 minutes with flowing water and see a doctor.
2. The toner in a printer cartridge contains a chemical material, which might harm human body if it is swallowed.

Please keep children out of the toner cartridge.

## **SAFETY PRECAUTIONS**

1. Be sure that all built-in protective devices are in place. Replace any missing protective shields.
2. Make sure there are no cabinet openings through which people-particularly children- might insert fingers or objects and contact dangerous voltages.
3. When re-installing chassis and assemblies be sure to replace all protective devices including control knobs and compartment covers.
4. Design Alteration Warning: Never alter or add to the mechanical or electrical design of this equipment, such as auxiliary connectors, etc. Such alterations and modifications will void the manufacturer's warranty.
5. Components, parts, and wiring that appear to have overheated or are otherwise damaged should be replaced with parts which meet the original specifications. Always determine the cause of damage or overheating, and correct any potential hazards.
6. Observe the original lead routing, especially near sharp edges, AC, and high voltage power sup-plies. Always inspect for pinched, out-of-place, or frayed wiring. Do not change the spacing between components and the printed circuit board.
7. Product Safety Notice: Some electrical and mechanical parts have special safety-related characteristics which might not be obvious from visual inspection. These safety features and the protection they provide could be lost if a replacement component differs from the original. This holds true, even though the replacement may be rated for higher voltage, wattage, etc.
8. Components critical for safety are indicated in the parts list with symbols  . Use only replacement components that have the same ratings, especially for flame resistance and dielectric specifications. A replacement part that does not have the same safety characteristics as the original may create shock, fire, or other safety hazards.

## ESD PRECAUTIONS

1. Certain semiconductor devices can be easily damaged by static electricity. Such components are commonly called “Electrostatically Sensitive (ES) Devices”, or ESDs. Examples of typical ESDs are: integrated circuits, some field effect transistors, and semiconductor “chip” components.

The techniques outlined below should be followed to help reduce the incidence of component damage caused by static electricity.

**CAUTION:** Be sure no power is applied to the chassis or circuit, and observe all other safety pre-cautions.

2. Immediately before handling a semiconductor component or semiconductor-equipped assembly, drain off any electrostatic charge on your body by touching a known earth ground. Alternatively, employ a commercially available wrist strap device, which should be removed for your personal safety reasons prior to applying power to the unit under test.
3. After removing an electrical assembly equipped with ESDs, place the assembly on a conductive surface, such as aluminum or copper foil, or conductive foam, to prevent electrostatic charge buildup in the vicinity of the assembly.
4. Use only a grounded tip soldering iron to solder or desolder ESDs. Use only an “anti-static” solder removal device. Some solder removal devices not classified as “anti-static” can generate electrical charges sufficient to damage ESDs.
5. Do not use Freon-propelled chemicals. When sprayed, these can generate electrical charges sufficient to damage ESDs.
6. Do not remove a replacement ESD from its protective packaging until immediately before installing it. Most replacement ESDs are packaged with all leads shorted together by conductive foam, aluminum foil, or a comparable conductive material.
7. Immediately before removing the protective shorting material from the leads of a replacement ESD, touch the protective material to the chassis or circuit assembly into which the device will be installed.
8. Maintain continuous electrical contact between the ESD and the assembly into which it will be installed, until completely plugged or soldered into the circuit.
9. Minimize bodily motions when handling unpack-aged replacement ESDs. Normal motions, such as the brushing together of clothing fabric and lifting one’s foot from a carpeted floor, can generate static electricity sufficient to damage an ESD.

## **SUPER CAPACITOR OR LITHIUM BATTERY PRECAUTIONS**

1. Exercise caution when replacing a super capacitor or Lithium battery. There could be a danger of explosion and subsequent operator injury and/or equipment damage if incorrectly installed.
2. Be sure to replace the battery with the same or equivalent type recommended by the manufacturer.
3. Super capacitor or Lithium batteries contain toxic substances and should not be opened, crushed, or burned for disposal.
4. Dispose of used batteries according to the manufacturer's instructions.

# TABLE OF CONTENTS

<b>1. INSTALLATION.....</b>	<b>1-1</b>
<b>2. PREVENTIVE MAINTENANCE .....</b>	<b>2-1</b>
<b>3. REPLACEMENT AND ADJUSTMENT .....</b>	<b>3-1</b>
3.1 GENERAL PRECAUTIONS ON DISASSEMBLY .....	3-1
Releasing Plastic Latches .....	3-1
3.2 REAR COVER .....	3-2
3.3 SCANNER ASS'Y .....	3-3
3.4 ADF ASS'Y .....	3-9
3.5 OPE ASS'Y (ALSO KNOWN AS 'OP-PORT').....	3-11
3.6 RIGHT COVER ASS'Y.....	3-12
Multi Purpose (MP) Tray (Also known as Bypass Tray) .....	3-13
Duplex Ass'y .....	3-14
Transfer Roller Ass'y.....	3-14
3.7 FUSER ASS'Y (ALSO KNOWN AS 'FUSING UNIT').....	3-15
3.8 EXIT ASS'Y.....	3-17
3.9 COPY TRAY .....	3-18
3.10 DRIVE ASS'Y.....	3-19
3.11 SMPS & HVPS (ALSO KNOWN AS 'PSU' AND 'POWER PACK).....	3-20
3.12 LSU (LASER SCANNING UNIT).....	3-21
3.13 LEFT COVER .....	3-22
3.14 MAIN FRAME ASS'Y .....	3-23
3.15 MP ASS'Y (MULTI PURPOSE ASS'Y) .....	3-25
3.16 FEED ASS'Y .....	3-27
3.17 PICK UP ASS'Y .....	3-28
3.18 MAIN BOARD .....	3-29
3.19 LIU BOARD .....	3-30
<b>4. TROUBLESHOOTING.....</b>	<b>4-1</b>
4.1 ERROR MESSAGES.....	4-1
4.2 ABNORMAL IMAGE PRINTING AND DEFECTIVE ROLLERS .....	4-3
4.3 TROUBLESHOOTING.....	4-4
4.3.1 SCANNER .....	4-4
COPY .....	4-4
PC-SCAN.....	4-5
4.3.2 FAX.....	4-6
FAX/TELEPHONE PRECAUTIONS.....	4-6

4.3.3 PRINT QUALITY .....	4-7
No Image .....	4-10
All Black .....	4-12
Vertical White Line (Band) .....	4-13
Dark Image.....	4-14
Background .....	4-15
Ghost .....	4-16
Black Spot.....	4-17
Horizontal Band.....	4-18
Irregular Density .....	4-19
White Spot.....	4-20
Trembling at the End When OHP Printing.....	4-21
Poor Fusing Grade.....	4-22
4.3.4 MALFUNCTION .....	4-23
No Power (LCD NO display LED Off).....	4-26
Fuser Error .....	4-27
Paper Jam (Mis-Feeding).....	4-28
Paper Jam (Jam 1).....	4-29
Engine Error .....	4-30
4.3.5 TONER CARTRIDGE AND DRUM CARTRIDGE SERVICE .....	4-31
Precautions on Safe-keeping of the Drum Cartridge.....	4-31
Service for the Life of Toner Cartridge .....	4-31
Symptoms of a defective toner cartridge .....	4-32
4.3.6 PROBLEMS CAUSED BY SOFTWARE .....	4-35
The printer is not working (1).....	4-35
The printer is not working (2).....	4-36
Abnormal Printing.....	4-37
Spooling Error .....	4-38
<b>5. SERVICE TABLES .....</b>	<b>5-1</b>
5.1 USER MODE .....	5-1
5.2 TECH MODE .....	5-3
5.2.1 HOW TO ENTER SERVICE MODE.....	5-3
5.2.2 SETTING UP THE SYSTEM IN TECH MODE.....	5-3
5.2.3 SYSTEM DATA.....	5-5
DIALING MODE .....	5-5
MODEM SPEED .....	5-5
ERROR RATE.....	5-5
SET TX LEVEL .....	5-5
SILENCE TIME .....	5-5
5.2.4 MEMORY CLEAR.....	5-6
CLEAR ALL MEMORY.....	5-6

5.2.5 MAINTENANCE.....	5-6
CLEAN DRUM .....	5-6
NOTIFY TONER LOW .....	5-6
SWITCH TEST .....	5-7
MODEM TEST .....	5-7
SRAM TEST .....	5-7
DRAM TEST .....	5-7
ROM TEST .....	5-7
PATTERN TEST .....	5-7
CLEAR COUNT .....	5-7
ANSWER ON CNG.....	5-8
ADJUST SHADING.....	5-8
FLASH UPGRADE.....	5-8
PROGRAM DIAL .....	5-8
REMOTE TEST .....	5-8
5.2.6 REPORTS/HELP.....	5-9
PROTOCOL DUMP LIST.....	5-9
SYSTEM DATA .....	5-9
5.3 IDENTIFY SALE DATE .....	5-9
5.4 FIRMWARE DOWNLOAD.....	5-10
5.4.1 LOCAL MACHINE UPDATE .....	5-10
RCP (Remote Control Panel) mode.....	5-10
To get the system data list .....	5-10
5.4.2 RECOVERY PROCEDURE.....	5-11
5.4.3 REMOTE MACHINE UPDATE .....	5-11
How to update firmware by remote fax .....	5-11
5.5 ENGINE TEST MODE.....	5-12
5.5.1 TO ENTER THE ENGINE TEST MODE .....	5-12
5.5.2 DIAGNOSTIC .....	5-12
5.5.3 STATUS PRINT.....	5-13
<b>6. DETAILED DESCRIPTION .....</b>	<b>6-1</b>
6.1 MAIN PBA (ALSO KNOWN AS MAIN BOARD) .....	6-1
6.1.1 SUMMARY .....	6-1
6.2 CIRCUIT OPERATION.....	6-2
6.2.1 FAX TRANSCEIVER .....	6-2
General.....	6-2
Modem (u44) .....	6-2
6.3 SCANNER.....	6-2
6.3.1 SUMMARY .....	6-2
CCD .....	6-2



6.3.2 KEY FEATURES.....	6-3
Overview .....	6-3
Pixel processing structure .....	6-3
Shading Correction .....	6-3
Gamma Correction.....	6-3
Binary conversion (mono) .....	6-4
Scaling of input image.....	6-4
Intelligent scan motor controller .....	6-4
Auto-Run.....	6-4
Processed data output format in DTM (Data Transfer Module).....	6-4
Others .....	6-4
6.4 SMPS & HVPS (ALSO KNOWN AS PSU AND POWER PACK).....	6-5
6.4.1 SUMMARY OF SMPS .....	6-5
6.4.2 SUMMARY OF HVPS.....	6-5
6.5 ENGINE CONTROLLER.....	6-5
6.5.1 FUSING CONTROL/THERMISTOR CIRCUIT.....	6-5
6.5.2 PAPER DETECTION CIRCUIT.....	6-6
1) Cover Open Detection .....	6-6
2) Paper Empty Detection .....	6-6
3) Paper Feeding .....	6-6
4) Paper Exit Detection .....	6-6
6.6 LIU (ALSO KNOWN AS NCU).....	6-7
6.6.1 SUMMARY.....	6-7
6.6.2 DIALER.....	6-7
TONE DIAL .....	6-7
PULSE DIAL .....	6-7

## **SPECIFICATIONS**

1. GENERAL SPECIFICATIONS.....	SPEC-1
2. PRINT SPECIFICATION.....	SPEC-2
3. SCAN SPECIFICATION .....	SPEC-2
4. COPY SPECIFICATION .....	SPEC-3
5. TELEPHONE SPECIFICATION.....	SPEC-3
6. FAX SPECIFICATION .....	SPEC-3
7. PAPER HANDLING .....	SPEC-4
8. CONSUMABLES .....	SPEC-4

## **APPENDIX**

BLOCK DIAGRAMS.....	APPENDIX-1
CONNECTION DIAGRAMS.....	APPENDIX-2

## **PARTS CATALOG**

---

# 1. INSTALLATION

Refer to the operating instructions.

## 2. PREVENTIVE MAINTENANCE

The replacement cycle interval shown below is for maintenance.

Environmental conditions and differences in how the machine is used will change this interval.

The cycle period shown is for reference only.

	<b>Component</b>	<b>Replacement Cycle</b>	<b>Done by</b>
<b>Scanner</b>	ADF Rubber Pad Ass'y	20,000 Pages	Service
	ADF Pick-up Ass'y	50,000 Pages	Service
<b>Printer</b>	Rubber - Paper Pick-up - Right	75,000 Pages	Service
	Rubber - Paper Pick-up - Left		
	Transfer Roller	75,000 Pages	Service
	Fuser	75,000 Pages	Service

Preventive Maintenance

---

## 3. REPLACEMENT AND ADJUSTMENT

### 3.1 GENERAL PRECAUTIONS ON DISASSEMBLY

When you disassemble and assemble components, you must use extreme caution.

Cables are near parts that move. Because of this, install the cables carefully. If components are removed, cables moved by the procedure must be put as near as possible to their initial positions. Before you remove a component from the machine, make a note of the cable routing that the procedure will have an effect on.

**Before you do work on the machine, you must do these steps:**

1. Make sure that no documents are stored in memory.
2. Disconnect the power cord.
3. Remove the toner and drum cartridges before you disassemble parts.
4. Use a flat and clean surface.
5. Replace only with approved components.
6. Be careful when you remove plastic components. Do not use force.
7. Make sure that all components are in their correct positions.

Replacement  
Adjustment

#### ***Releasing Plastic Latches***

Many parts set in their positions with plastic latches. The latches break easily. Release them carefully. Push the hook end of the latch away from the part to which it is latched to remove these parts.

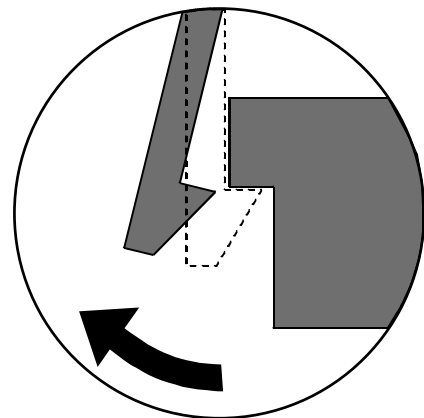

B174R979.WMF

### 3.2 REAR COVER

1. Remove the six screws that hold the Rear Cover.

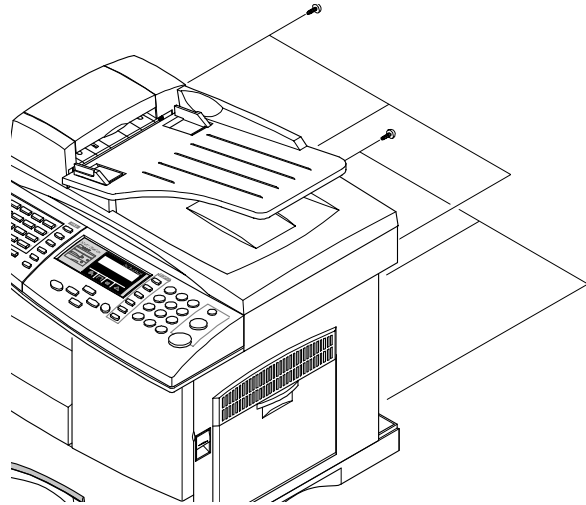

B174R900.WMF

2. Remove the Rear Cover [A] as shown.

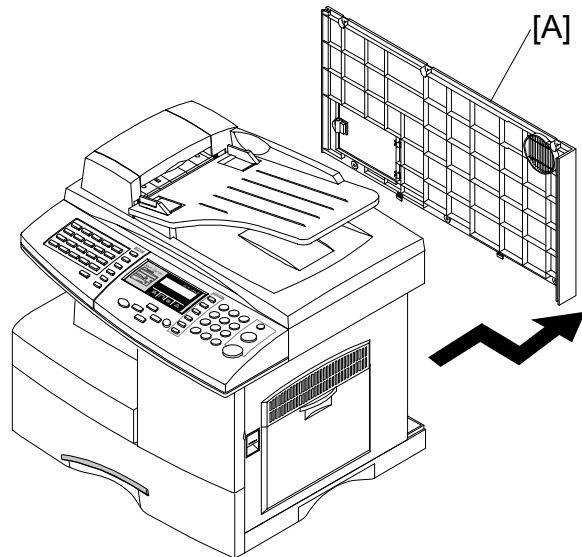

B174R901.WMF

### 3.3 SCANNER ASS'Y

1. Before you remove the Scanner Ass'y [A], you must remove:  
- Rear Cover (☛3.2)
2. Disconnect the connector and the CCD cable [B].  
**NOTE:** To prevent damage to the CCD cable connector, pull the cable out carefully. Pull in a line with the connector, not at an angle.

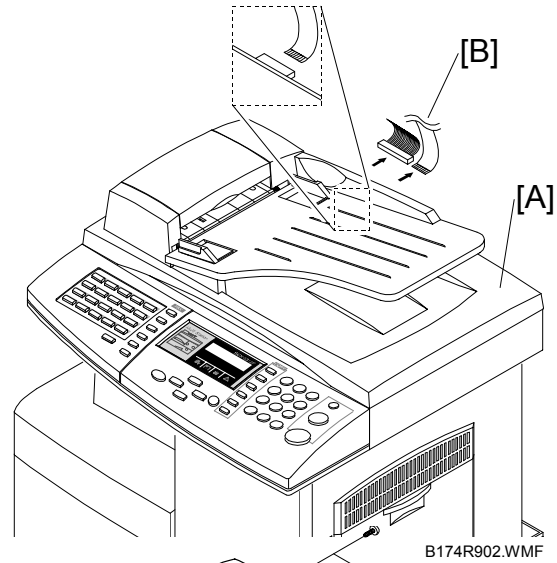

B174R902.WMF

3. Remove the three screws, as shown.

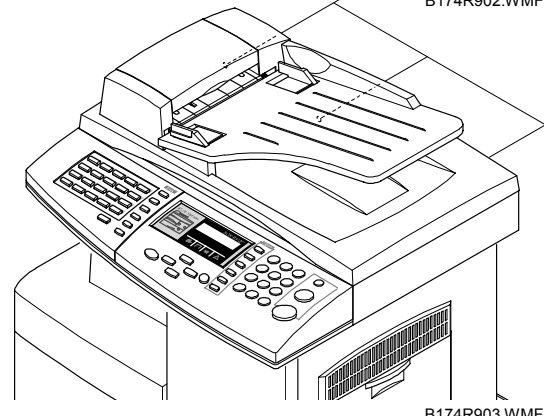

B174R903.WMF

4. Open the Right Cover assembly [C] first to open the Front Cover [D].
  - Close the front cover first when you assemble the machine.

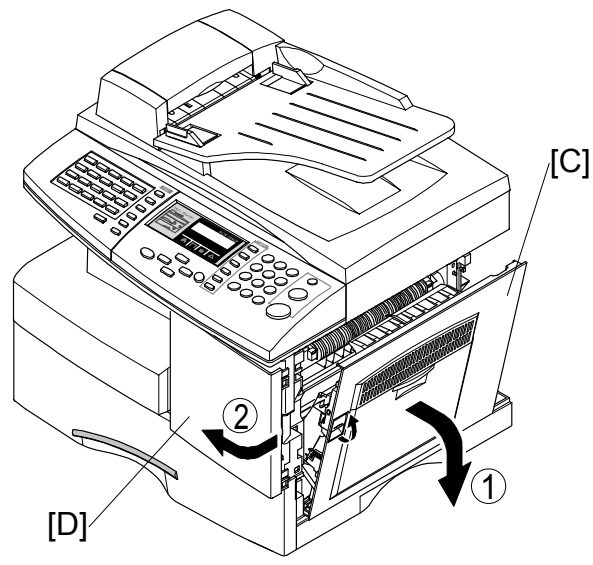

B174R904.WMF

5. Remove two screws.

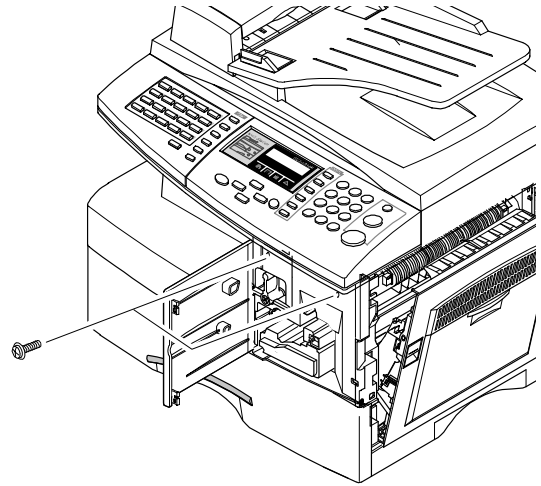

B174R905.WMF

6. Pull up the Scanner Ass'y [A] in the direction of the arrow.

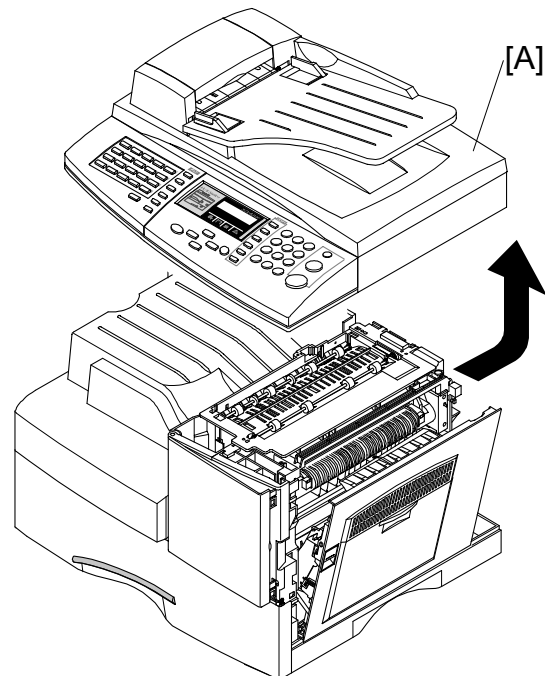

B174R906.WMF

7. Disconnect the connector [B] from the Platen Ass'y.

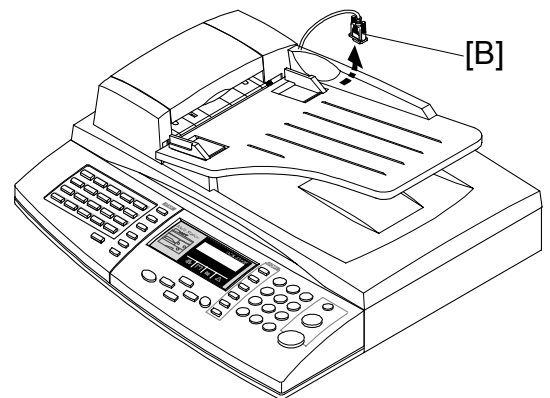

B174R907.WMF

8. Open the Platen Ass'y [A] as shown by the arrow.  
Pull up the Platen Ass'y and remove it.

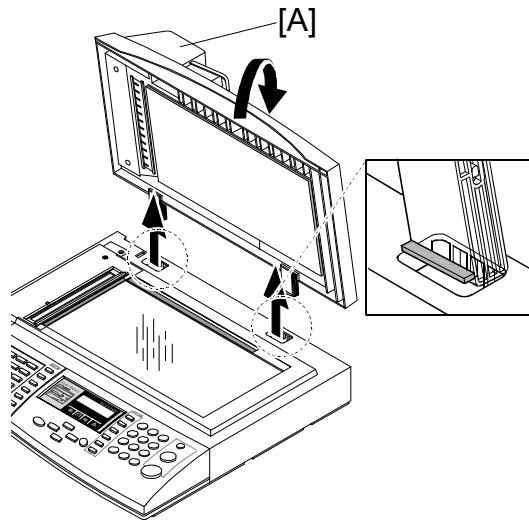

B174R909.WMF

Replacement  
Adjustment

9. Remove the three screws securing the Platen Ass'y.

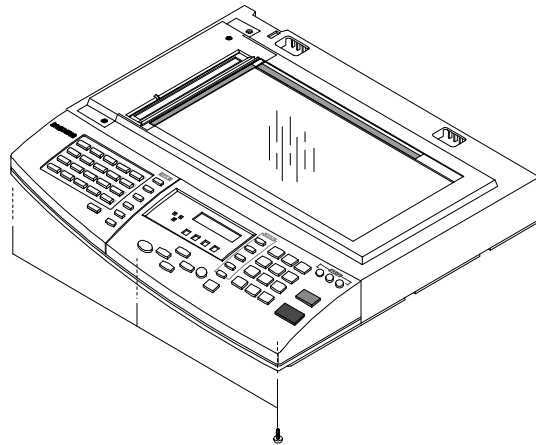

B174R908.WMF

10. Pull up the OPE Ass'y [B] and remove it (x 1).

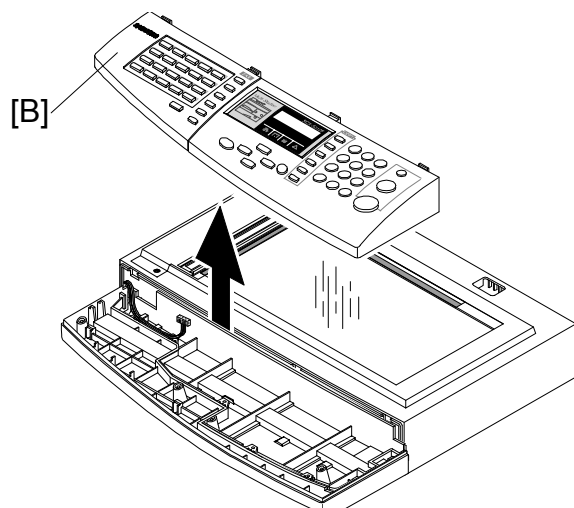

B174R978.WMF



11. Remove the five screws that hold the Scan Upper Ass'y [A].

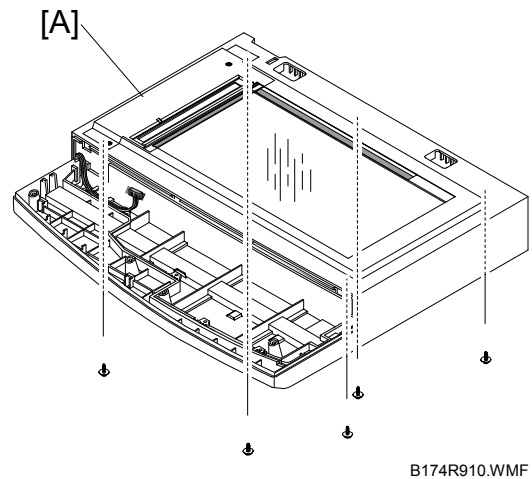

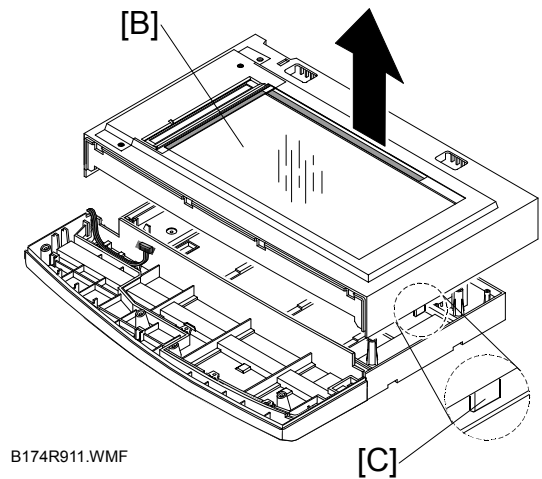

12. Remove the Scan Upper Ass'y that holds the platen glass [B]. (Release one hook [C].)

**NOTE:** When you disassemble the Scan Ass'y, make sure that your work area is clean. Dirt or dust on the scan head can cause unsatisfactory scanned image quality.

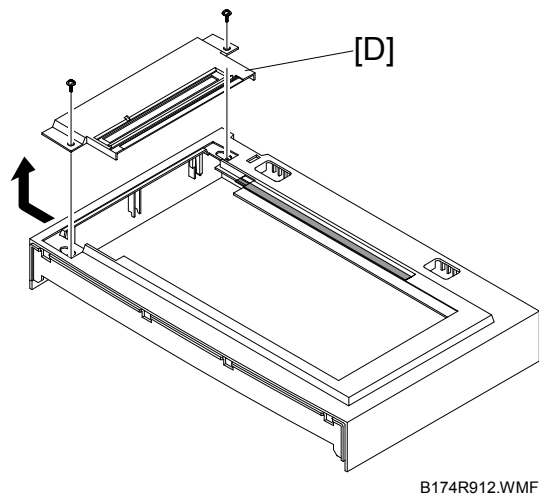

13. Remove the Dummy Upper Ass'y [D] (x 2).



14. Remove the Channel Base Frame [A]  
( x 4).

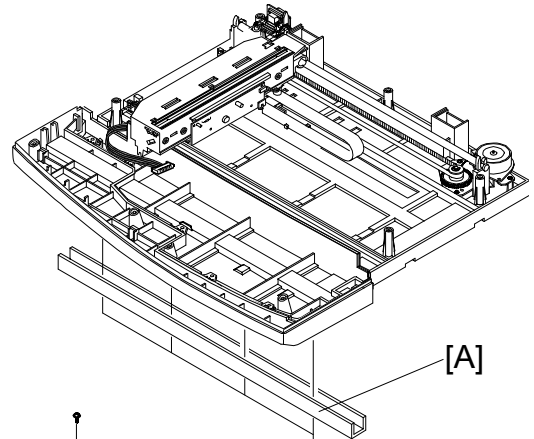

15. Remove the Dummy Scan-Lower [B]  
( x 5).

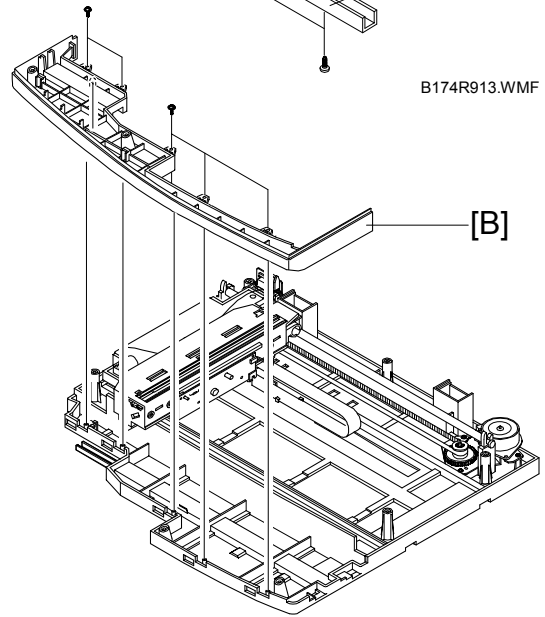

Replacement  
Adjustment

16. Remove the CCD cable [C].

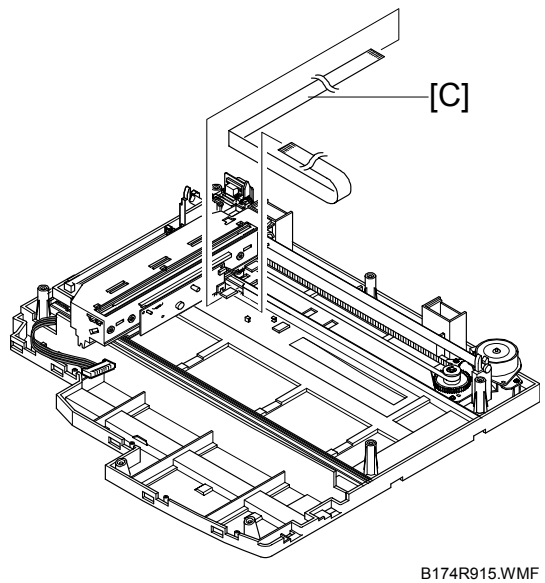

17. Pull up the Shaft CCD [A], and remove the Scanner Unit [B].

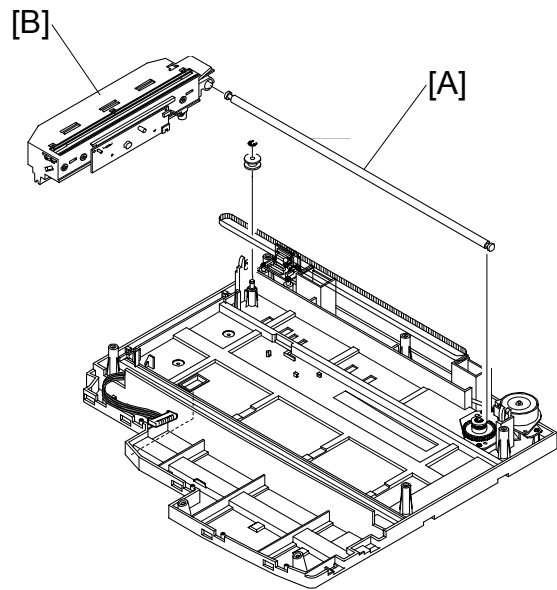

18. Remove the Motor Bracket [C] (⚙ x 3).

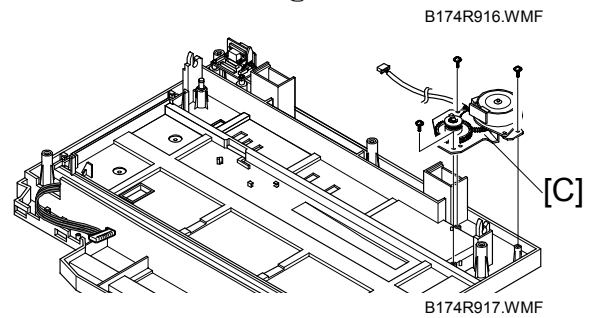

19. Disconnect the OPE Harness [D] from the Platen board [E]. Remove the Platen board (⚙ x 2).

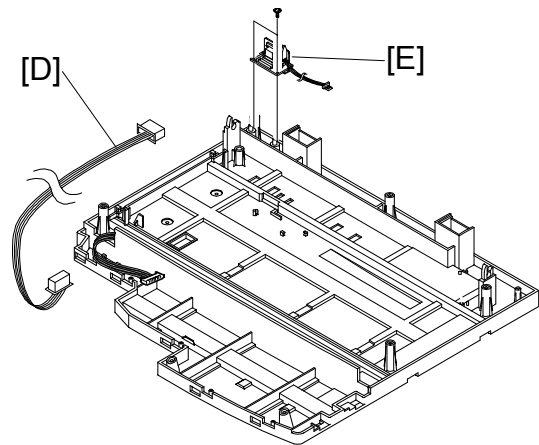

**NOTE:** Be very careful when you attach the CCD Unit back to the Platen Ass'y. The CCD Unit is on the right side of the Belt Tension Spring [F].

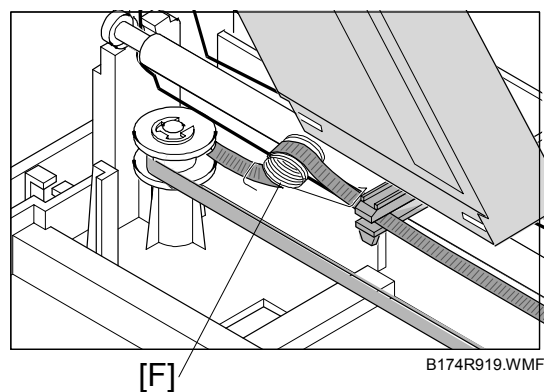

### 3.4 ADF ASS'Y

1. Before you remove the ADF Ass'y [A], you must remove:
  - Rear Cover (☛ 3.2)
  - Scanner Ass'y (☛ 3.3)
2. Remove the five screws from the Platen Ass'y.

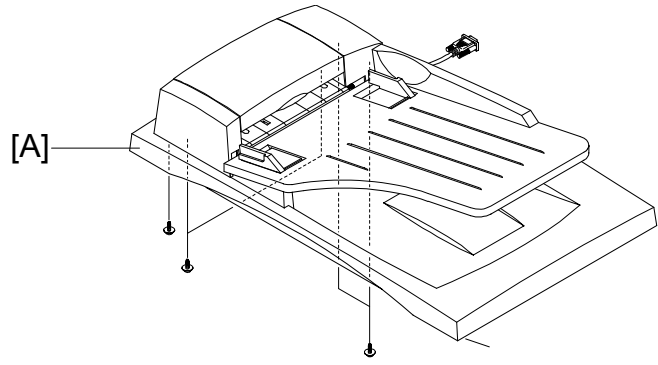

B174R920.WMF

Replacement  
Adjustment

3. Open the ADF Upper Cover [B]. Remove Side Cover R [C]. Release Side Cover L [D]. To do this, use a sharp tool or small screwdriver as shown [E]. Then remove Side Cover L.

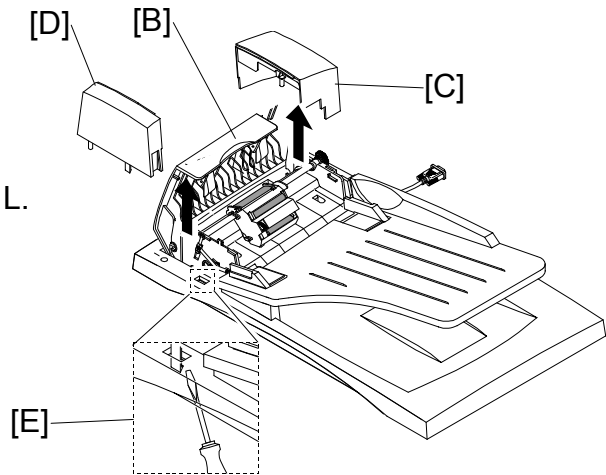

B174R921.WMF

4. Pull up the ADF Ass'y [F] and remove it.

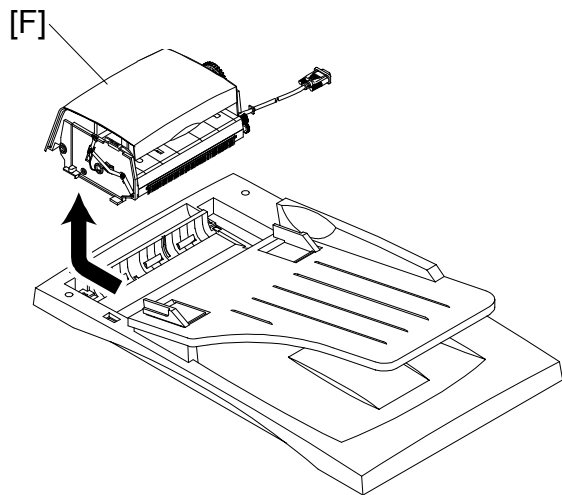

B174R922.WMF

5. Remove the ADF Upper Cover [A].

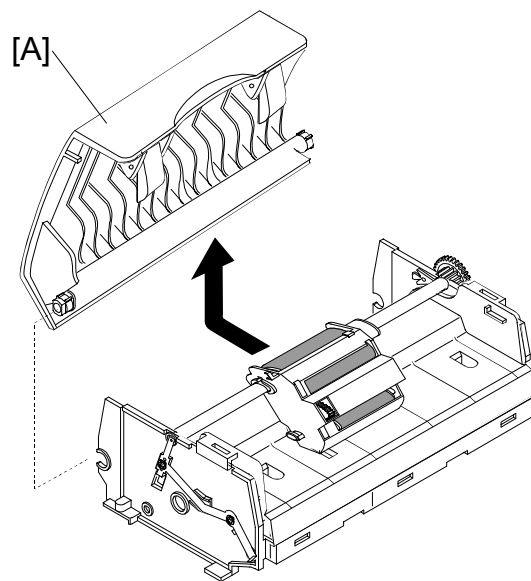

B174R923.WMF

6. Remove the ADF Pick-up Ass'y [B] (⚙️ 2). Remove the ADF Upper [C] (⚙️ x 4).

[D]: ADF Rubber Pad Ass'y (⚙️ 2)

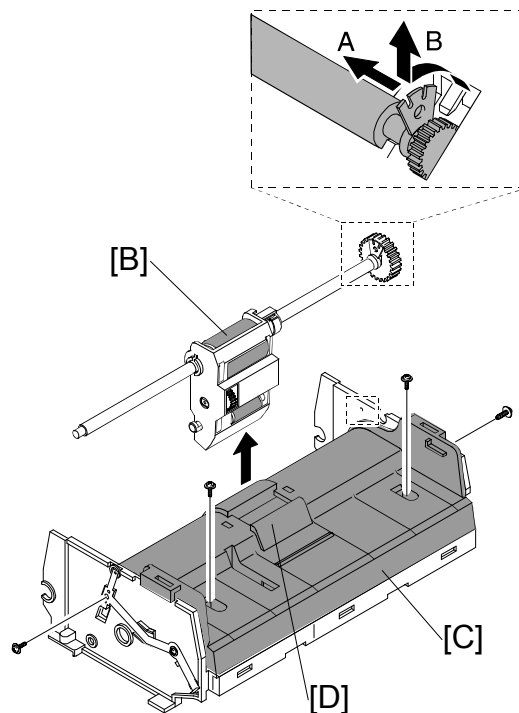

B174R924.WMF

7. Remove the ADF Motor ass'y [E] (⚙️ x 3).

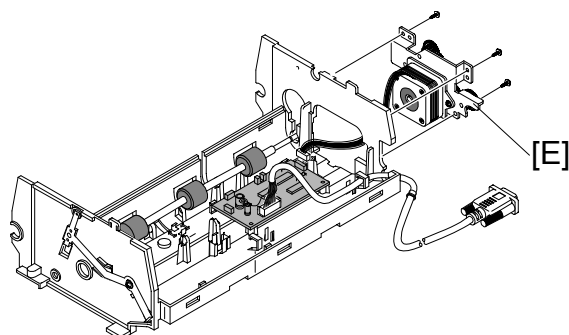

B174R925.WMF

### 3.5 OPE ASS'Y (ALSO KNOWN AS 'OP-PORT')

1. Before you remove the OPE Ass'y, you must remove:
  - Rear Cover (☛ 3.2)
  - Scanner Ass'y (☛ 3.3)
2. Remove the OPE board [A] and the LCD Module [B] from the OPE Cover [C] (⚙ x 10).

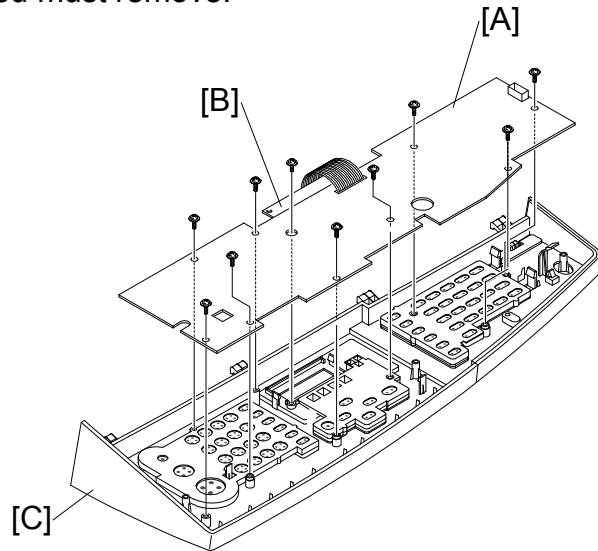

B174R926.WMF

3. Remove the contact rubbers [D] from the unit.

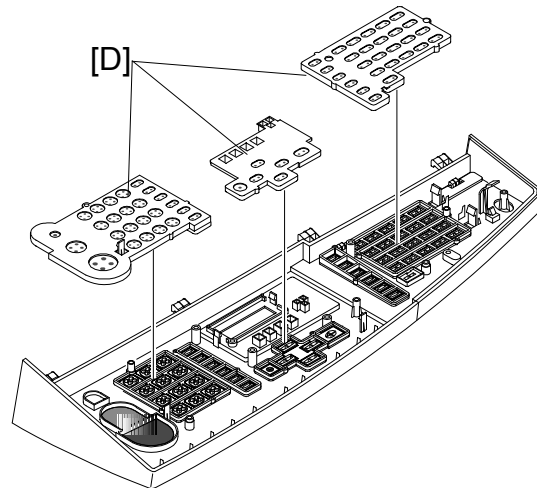

B174R927.WMF

4. Remove the key pad [E] from the unit.

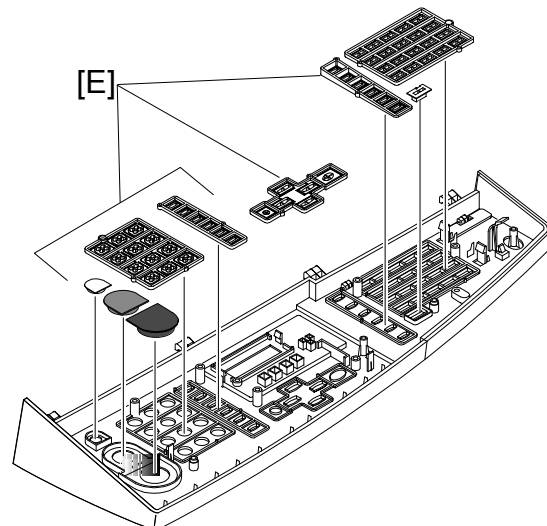

B174R928.WMF

### 3.6 RIGHT COVER ASS'Y

1. Remove two screws to release the Stopper [A] (Main Frame side) that holds the Right Cover [B] to the Main Frame.

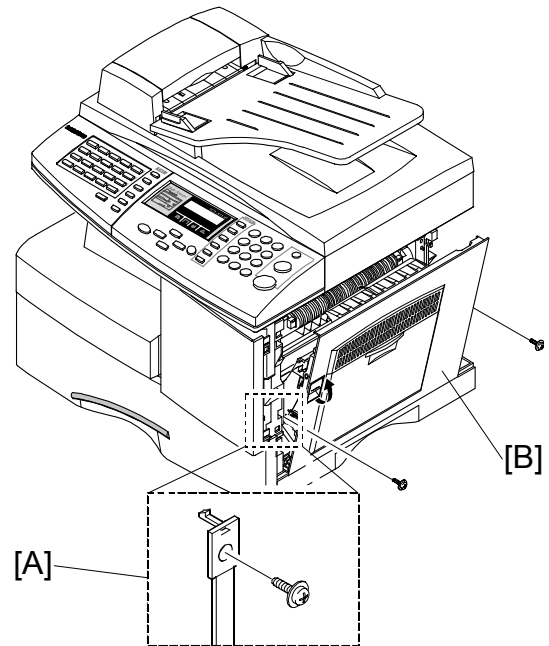

B174R929.WMF

2. Fully open the Right Cover door [C]. Lift the left hand hinge ① to release it. Then push the door assembly to the left to release the right hand hinge ②.

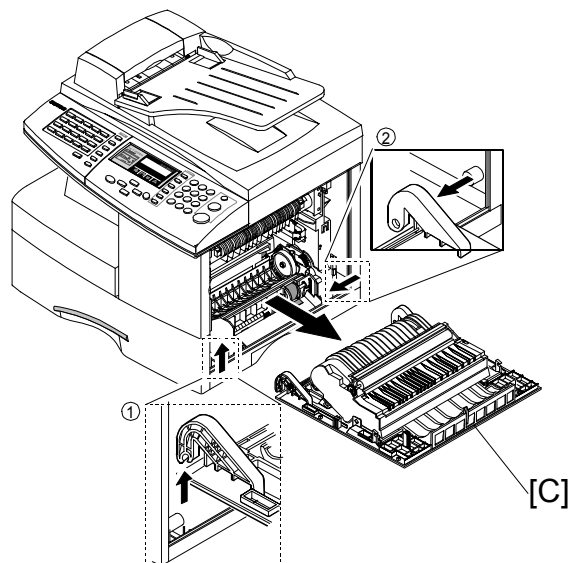

B174R930.WMF

**Multi Purpose (MP) Tray (Also known as Bypass Tray)**

1. To disassemble the MP tray, release the lower hinges ①.

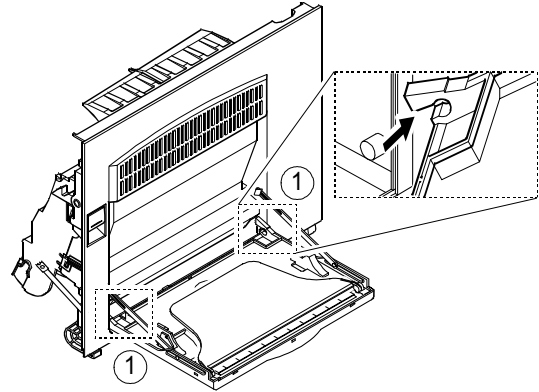

B174R931.WMF

2. As shown at ①, align the door supports in a horizontal position. This will let you remove the Tray-Case [A] from the Tray Links [B]. To remove the Tray-Links [B], adjust the position of the Tray Links to a 45-degree angle to align the slot in the link correctly, as shown at ②.

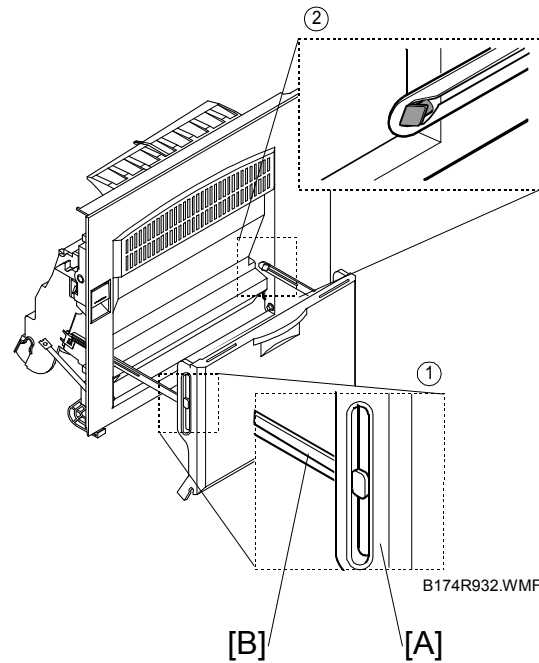

B174R932.WMF

Replacement  
Adjustment



**Duplex Ass'y**

1. Remove the Duplex Ass'y [A] from the Side Door Ass'y [B] (release the plastic clips, 2 on each side).

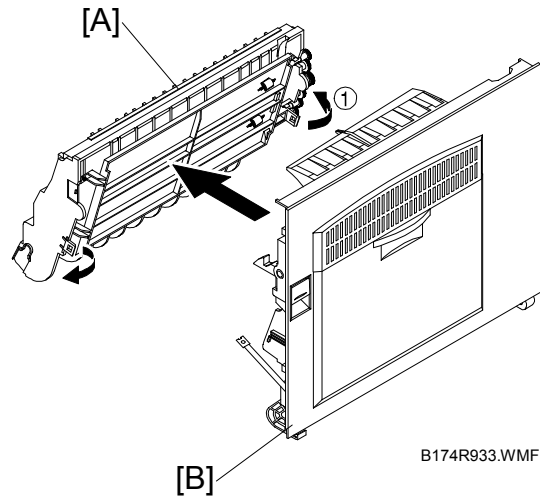

**Transfer Roller Ass'y**

1. Remove the Transfer Roller Ass'y [B] (2).

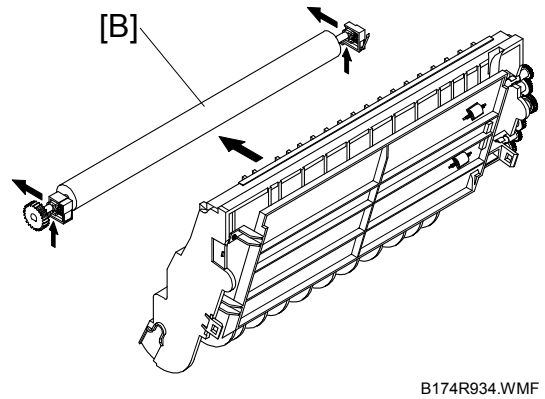

### 3.7 FUSER ASS'Y (ALSO KNOWN AS 'FUSING UNIT')

#### ⚠ CAUTION

The fusing unit has tapping screws. Assembly/disassembly should be kept to a minimum. Adjustments again and again can cause failure. To avoid hazardous situations, do not replace any components inside the fusing unit such as thermistor, thermostat, hot roller, stripper pawls, fusing lamp, etc.

1. Before you remove the Fuser Ass'y, you must make sure that power is off. Then remove:
  - Rear Cover Ass'y (☛ 3.2)
  - Right Cover Ass'y (☛ 3.6)
2. Remove the Connector Cover [A] and the Cover Bracket [B] (☛ x 1 each).

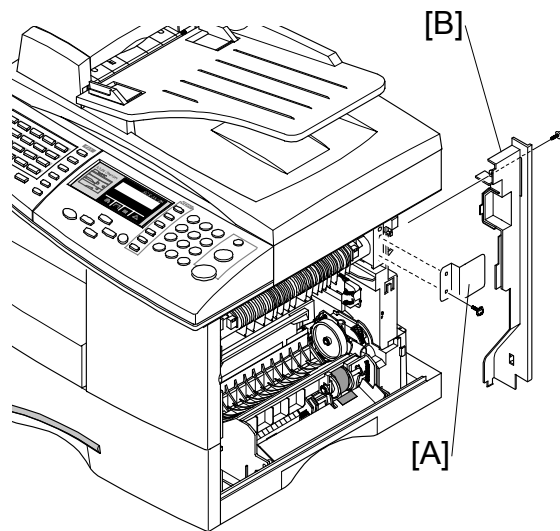

B174R935.WMF

3. Disconnect one connector [C].

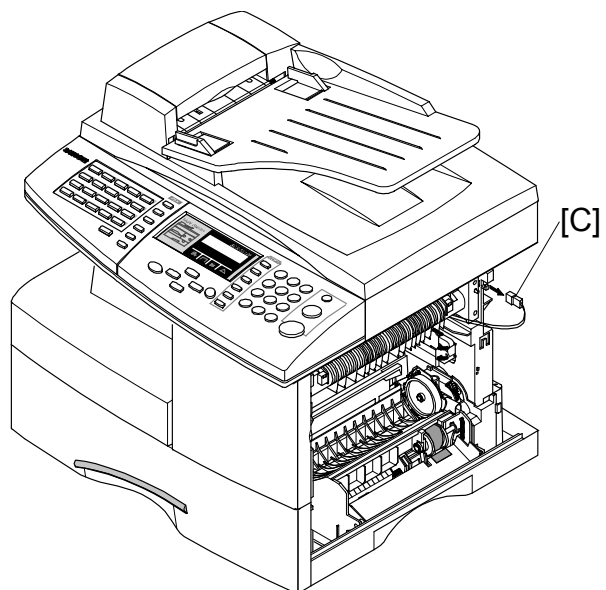

B174R936.WMF

Replacement  
Adjustment

4. Remove the Fuser Ass'y [A] (⚙️ x 3).  
(👉 2)

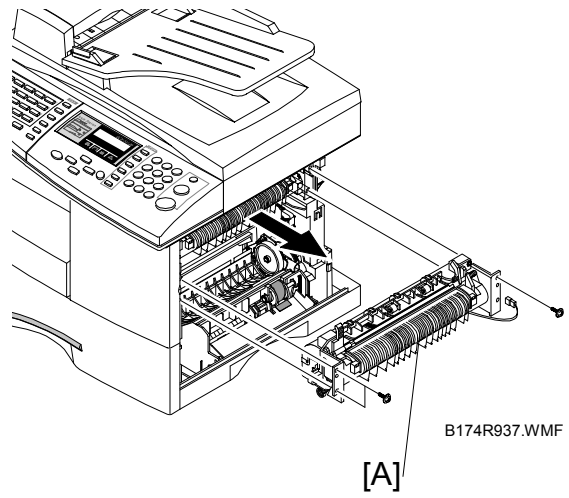

### 3.8 EXIT ASS'Y

1. Before you remove the Exit Ass'y, you must remove:
  - Rear Cover (☞ 3.2)
  - Scanner Ass'y (☞ 3.3)
2. Remove four screws. Then, remove the harness from the Exit Upper. Disconnect four connectors and unlatch the Dummy Base Frame [A], as shown.

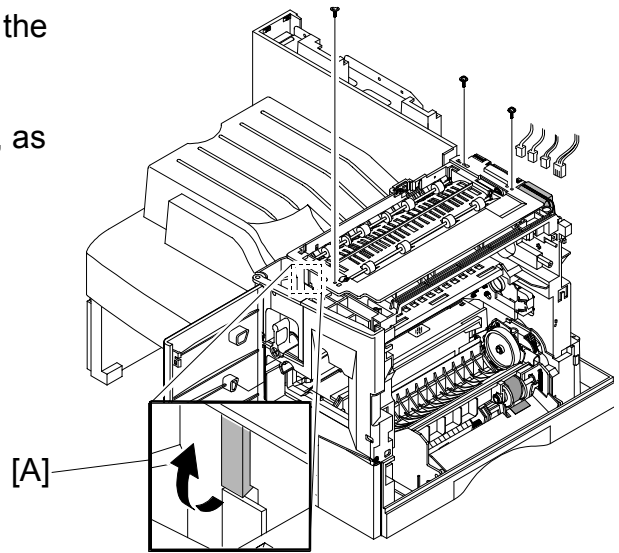

Replacement Adjustment

B174R941.WMF

3. Move the Exit Roller Release Lever [B] to the vertical position as shown in the diagram. Then, lift the Exit Ass'y [C] to remove it.

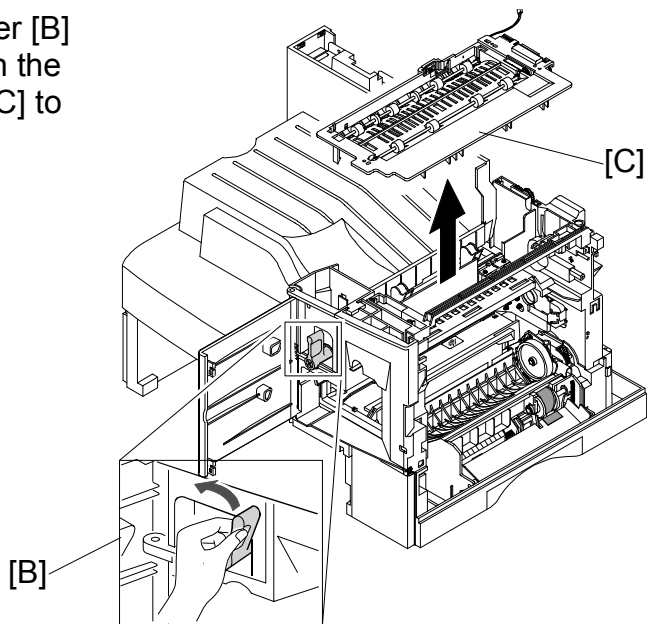

B174R942.WMF

### 3.9 COPY TRAY

1. Before you remove the Copy Tray, you must remove:
  - Rear Cover (☛ 3.2)
  - Scanner Ass'y (☛ 3.3)

2. Remove the Copy Tray [A] (🔩 x 2).

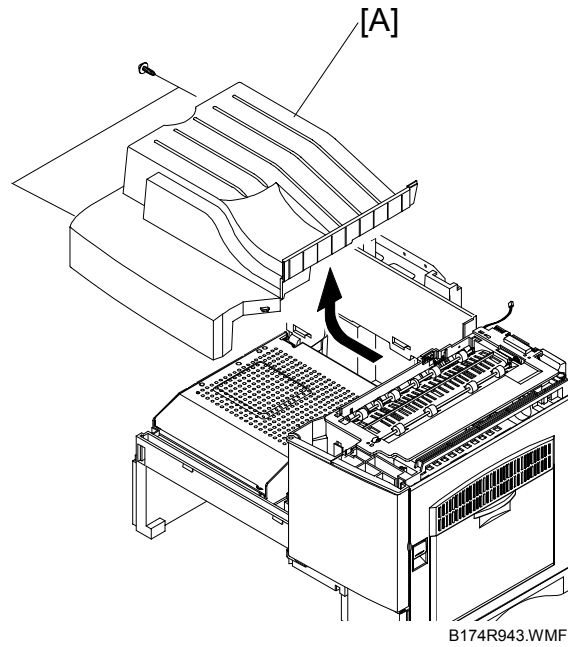

B174R943.WMF

### 3.10 DRIVE ASS'Y

1. Before you remove the Drive Ass'y, you must remove:
  - Rear Cover (☞ 3.2)
  - Shield Main Upper (☞ 3.3)
2. Unplug two connectors.  
(for Main Motor [A]: 9-pin, for Duplex Solenoid [B]: 2-pin)

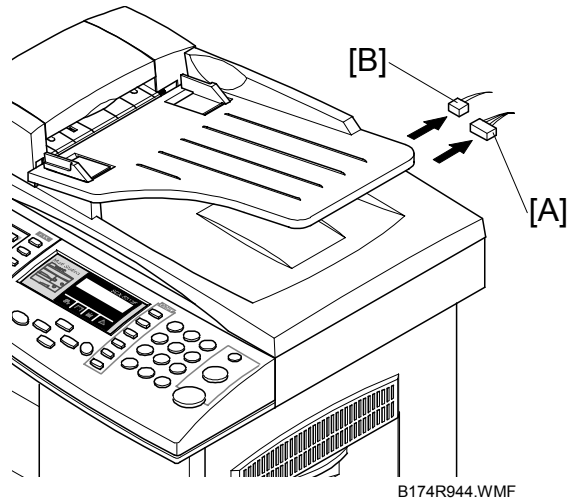

Replacement Adjustment

3. Remove the Fan [C] and Duct - Fan [D] (⚙ x 1).

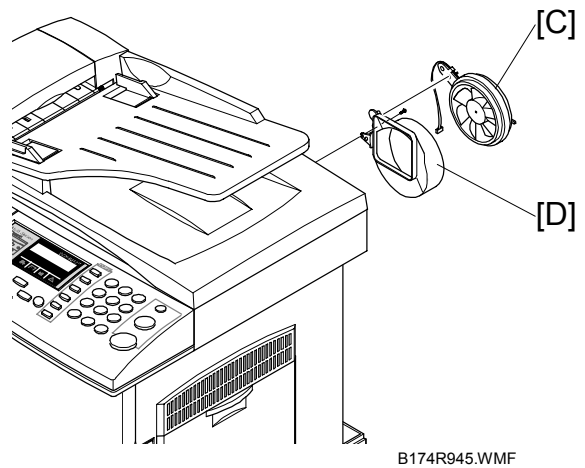

4. Remove the Drive Ass'y [E] (⚙ x 5).

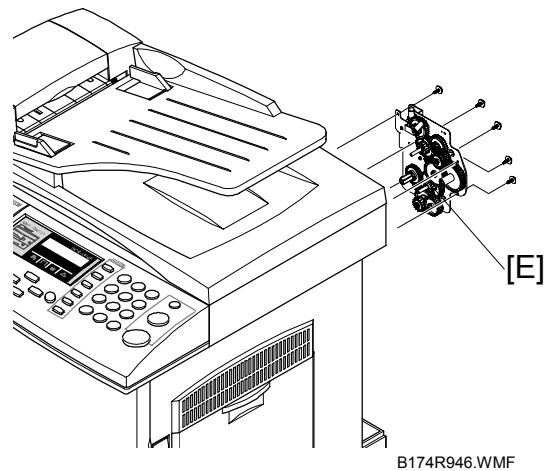

### 3.11 SMPS & HVPS (ALSO KNOWN AS 'PSU' AND 'POWER PACK')

1. Before you remove the SMPS & HVPS, you must remove:
  - Rear Cover (☛ 3.2)
  - Scanner Ass'y (☛ 3.3)
  - Copy Tray (☛ 3.9)
2. Remove the Shield SMPS Upper [A] (⚙ x 3).

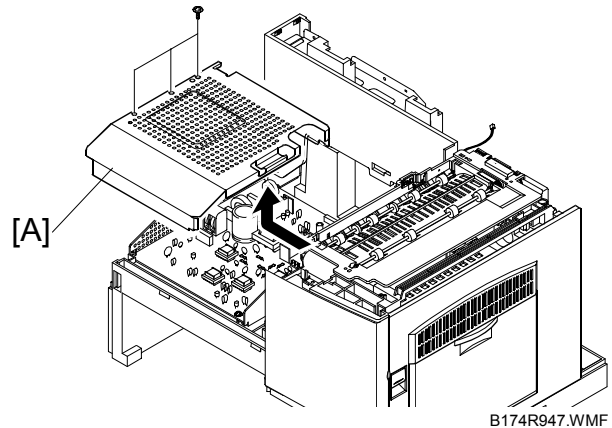

3. Disconnect all the connectors.

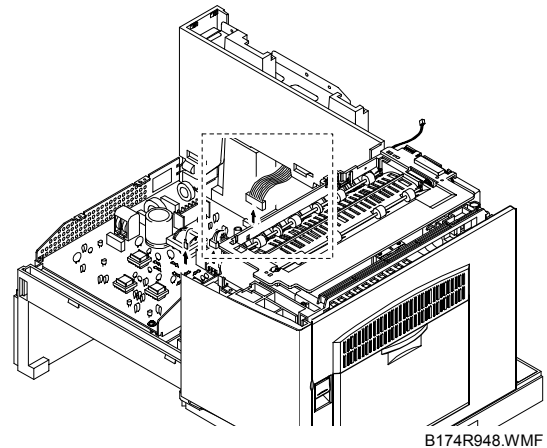

4. Remove the SMPS & HVPS [B].

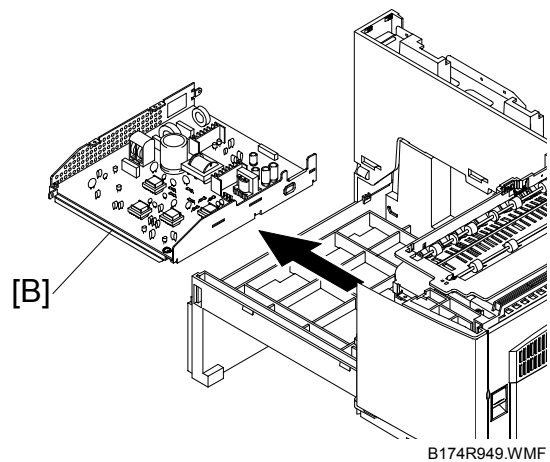

### 3.12 LSU (LASER SCANNING UNIT)

1. Before you remove the LSU, you must remove:
  - Rear Cover (☛ 3.2)
  - Scanner Ass'y (☛ 3.3)
  - Copy Tray (☛ 3.9)
2. Disconnect two connectors.

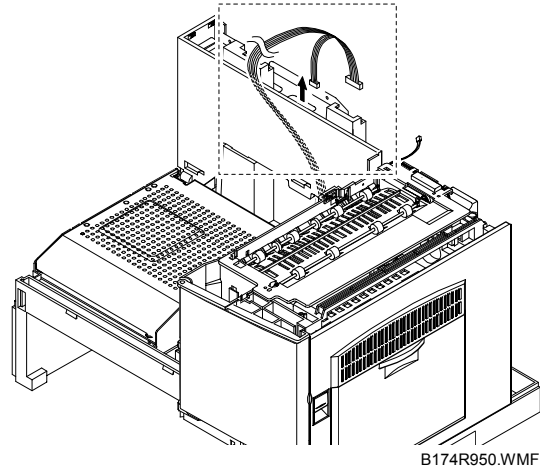

Replacement  
Adjustment

3. Remove the LSU [A] (☛ x 3).

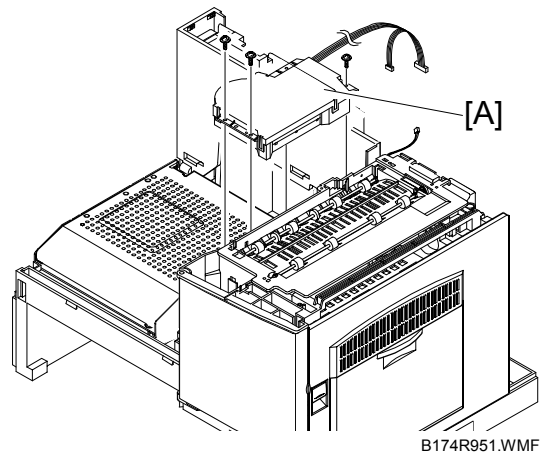



### 3.13 LEFT COVER

1. Before you remove the Left Cover, you must remove:
  - Rear Cover (☞ 3.2)
  - Scanner Ass'y (☞ 3.3)
  - Exit Ass'y (☞ 3.8)
  - Copy Tray (☞ 3.9)
  - SMPS (☞ 3.11)
2. Remove the Interface Panel [A]  
(☞ x 1).

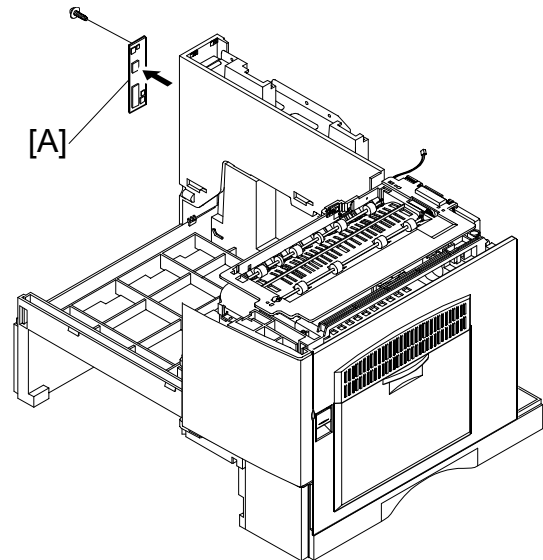

B174R952.WMF

3. Remove the Left Cover [B] (☞ x 1).

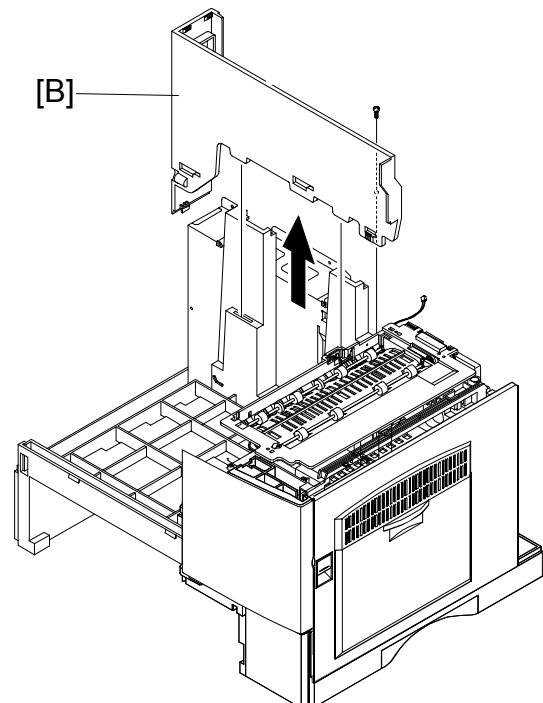

B174R953.WMF

### 3.14 MAIN FRAME ASS'Y

1. Before you remove the LSU, you must remove:

- Rear Cover (☞ 3.2)
- Scanner Ass'y (☞ 3.3)
- Right Cover Ass'y (☞ 3.6)
- Fuser (☞ 3.7)
- Exit Ass'y (☞ 3.8)
- Copy Tray (☞ 3.9)
- SMPS (☞ 3.11)
- LSU (☞ 3.12)

2. Remove the Dummy Base Frame [A] (⚙ x 5), the Front Cover [B], and the Paper Exit Cam [C].

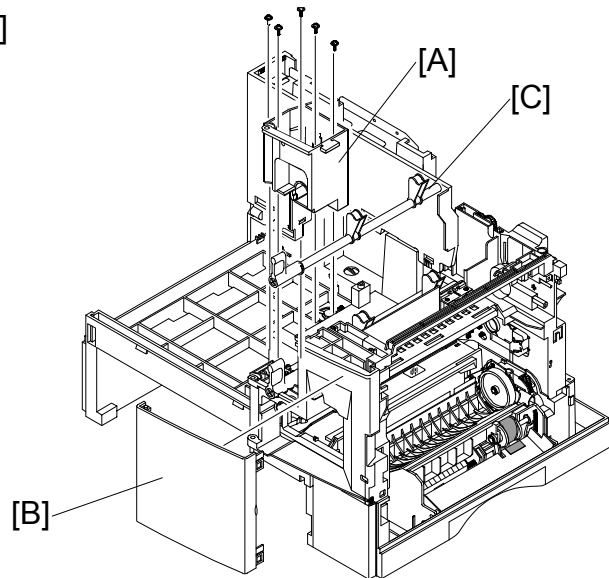

Replacement  
Adjustment

B174R954.WMF

3. Remove the Deve Lock Lever [D]. Then remove the Cover Motor Bracket [E] (⚙ x 1).

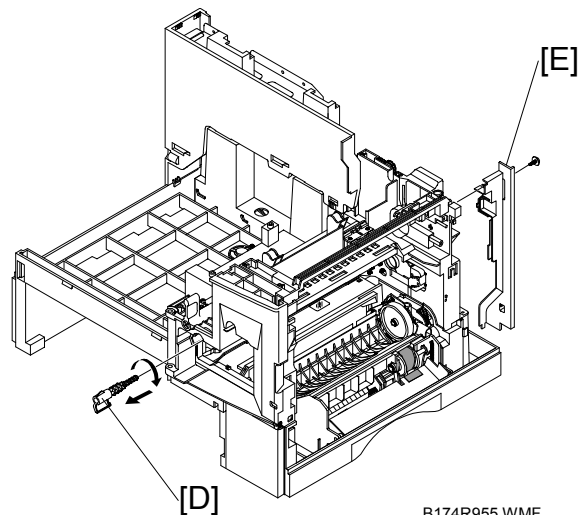

B174R955.WMF

4. Disconnect all the connectors.

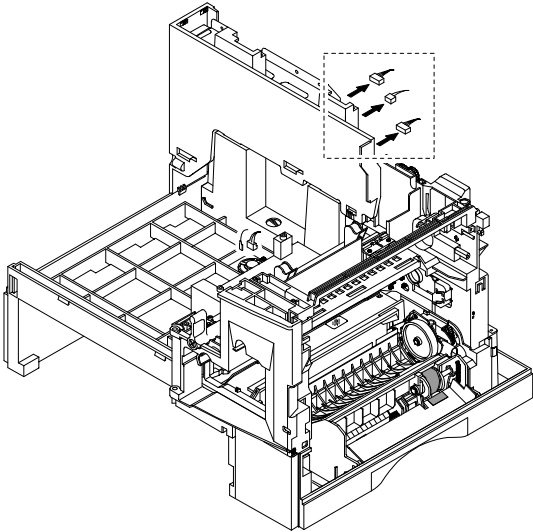

B174R956.WMF

5. Remove the Main Frame Ass'y [A] (⌀ x 7).

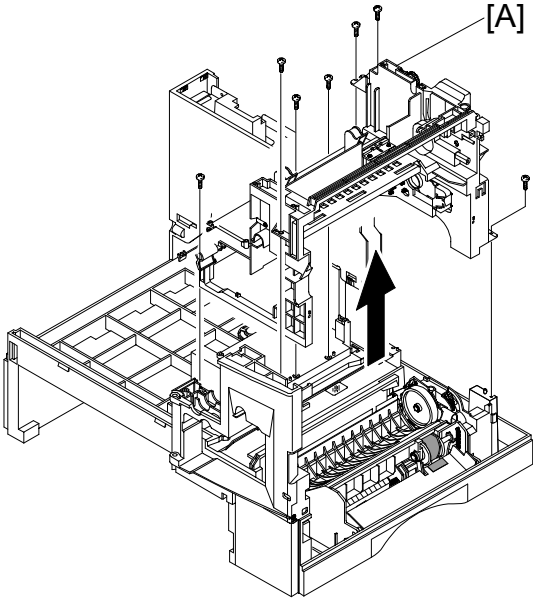

B174R957.WMF

### 3.15 MP ASS'Y (MULTI PURPOSE ASS'Y)

1. Before you remove the MP Ass'y, you must remove:
  - Rear Cover (☛ 3.2)
  - Shield Main Upper (☛ 3.3)
  - Right Cover Ass'y (☛ 3.6)
2. Disconnect two connectors.

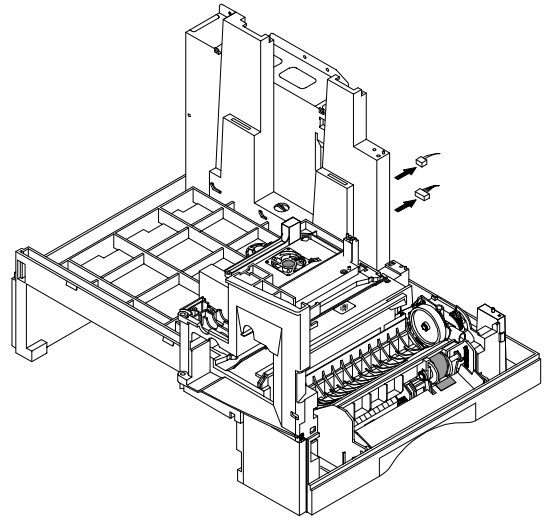

Replacement  
Adjustment

B174R958.WMF

3. Remove the Feed Cover [A] (☛ x 1).

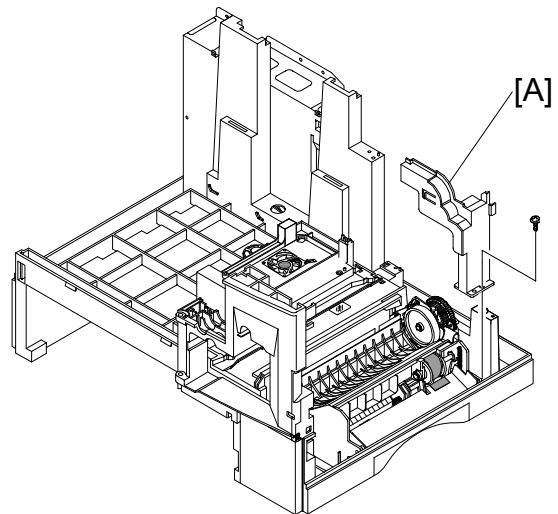

B174R959.WMF

4. Remove three screws.

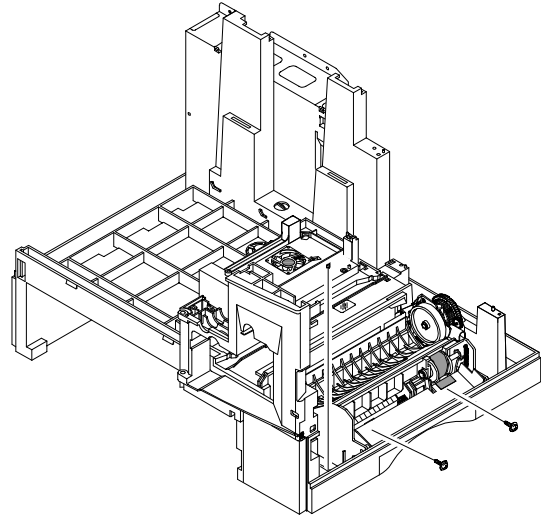

B174R960.WMF

5. Release the SMPS by hand from below, as shown. Pull the MP Ass'y [A] up and remove it.

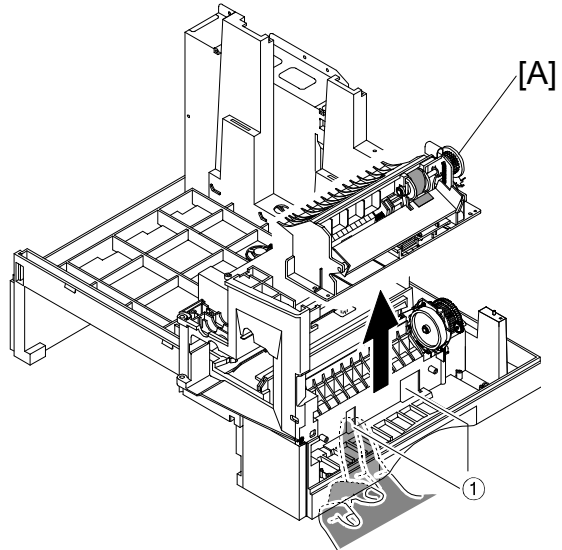

B174R961.WMF

## 3.16 FEED ASS'Y

1. Before you remove the Feed Ass'y, you must remove:
  - Rear Cover (☛ 3.2)
  - Scanner Ass'y (☛ 3.3)
  - Right Cover Ass'y (☛ 3.6)
  - Exit Ass'y (☛ 3.8)
  - Copy Tray (☛ 3.9)
  - LSU (☛ 3.12)
  - Main Frame Ass'y (☛ 3.14)
2. Remove three screws.

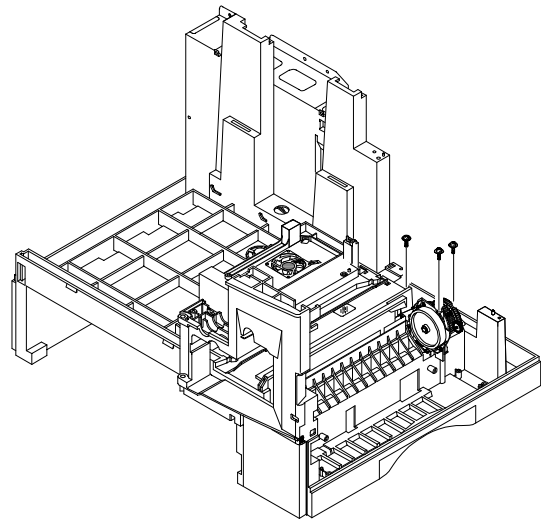

B174R962.WMF

Replacement  
Adjustment

3. Pull the Feed Ass'y [A] up and remove it.

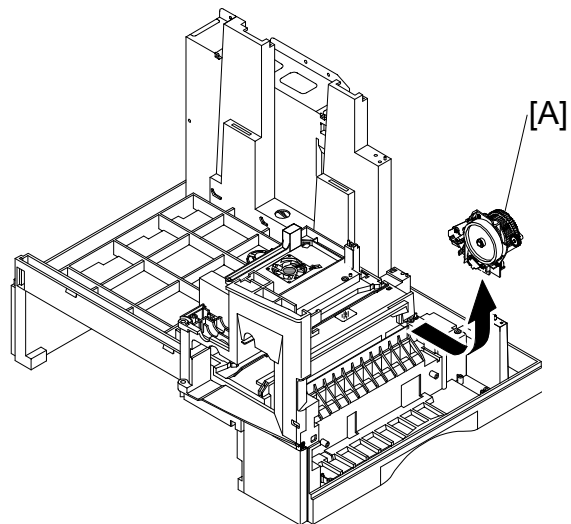

B174R963.WMF

### 3.17 PICK UP ASS'Y

1. Before you remove the Pick Up Ass'y, you must remove:
  - Rear Cover (☛ 3.2)
  - Shield Main Upper (☛ 3.3)
  - Drive Ass'y (☛ 3.10)
2. Disconnect three connectors.

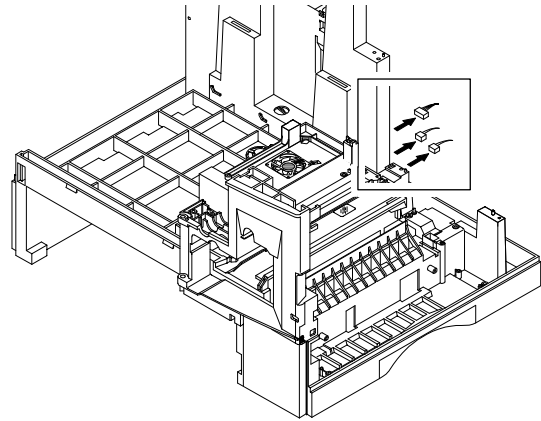

B174R964.WMF

3. Remove the Cassette Rail [A] (☛ x 2).

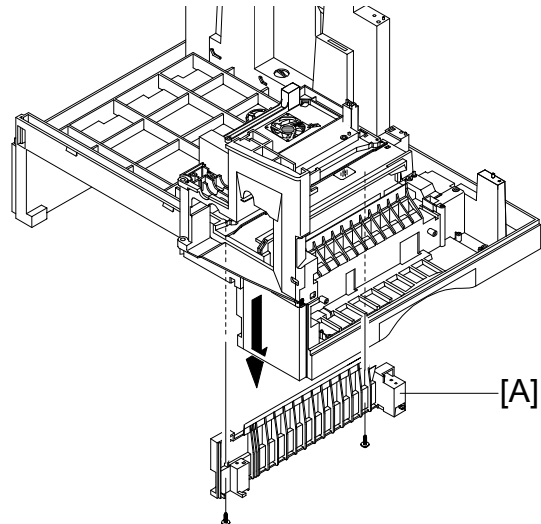

B174R965.WMF

4. Remove the Pick Up Ass'y [B] (☛ x 4).

[C]: Rubber – Paper Pick-up (☛ 2)

[D]: Quenching (PTL) Lamp

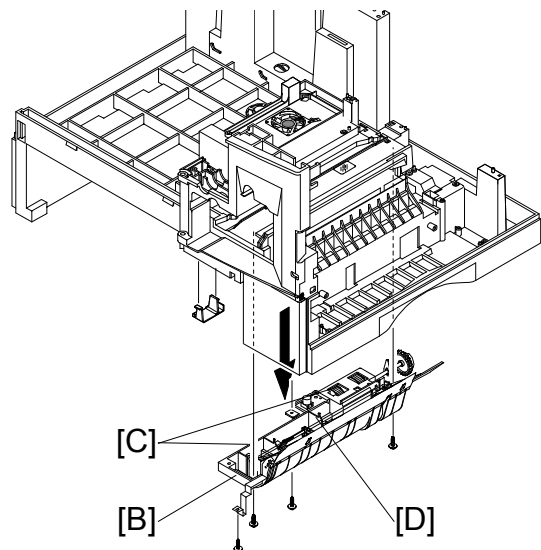

B174R966.WMF

### 3.18 MAIN BOARD

1. Before you remove the Main Board, you must remove:
  - Rear Cover (☛ 3.2)
  - Right Cover Ass'y (☛ 3.6)
  - Copy Tray (☛ 3.9)
  - SMPS (☛ 3.11)
2. Remove the Shield Plate [A] (☛ x 2).

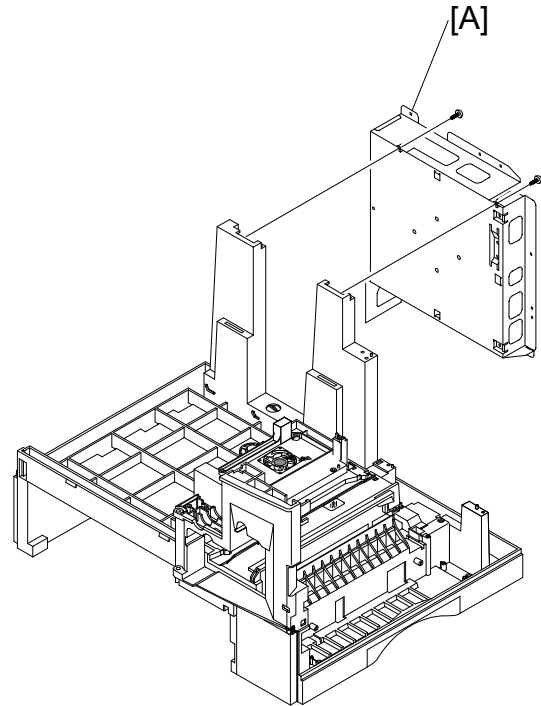

Replacement  
Adjustment

B174R967.WMF

3. Remove the Main Board [B] from the Shield Plate (☛ x 5).

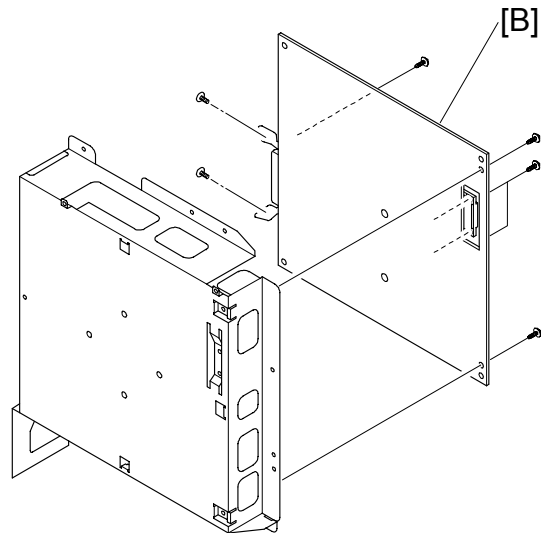

B174R968.WMF

**NOTE:** Do a memory clear after you replace the main board. If not, the system possibly will not operate correctly. (☛ 5.2.4)



### 3.19 LIU BOARD

1. Before you remove the LIU Board, you must remove:

- Rear Cover (☛ 3.2)
- Right Cover Ass'y (☛ 3.6)
- Copy Tray (☛ 3.9)
- SMPS (☛ 3.11)
- Main Board (☛ 3.18)

2. Remove one screw and unlatch the LIU Board [A] from the Main Board [B].

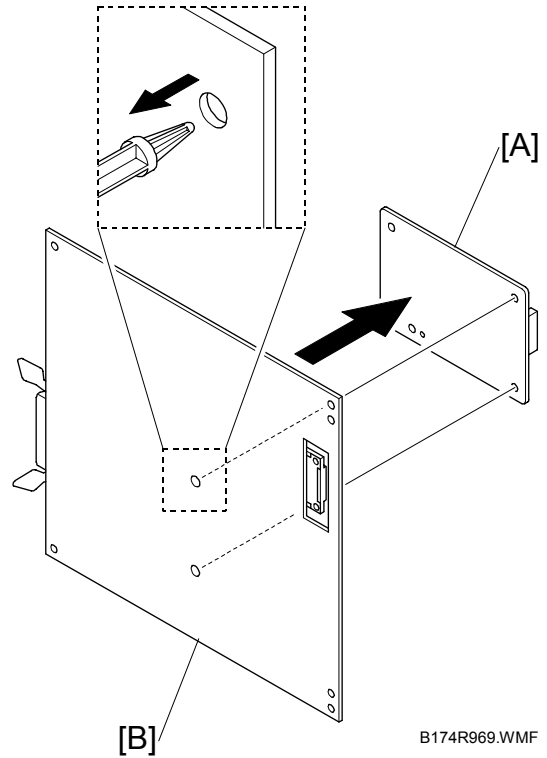

B174R969.WMF

## 4. TROUBLESHOOTING

This chapter includes problem diagnosis and troubleshooting. It shows how to find and repair print quality problems.

### 4.1 ERROR MESSAGES

Error Message	Description	Solution
RETRY REDIAL?	The machine is waiting for the programmed interval to automatically redial.	You can press START to immediately redial, or STOP to cancel the redial operation.
COMM. ERROR	A problem with fax communications has occurred.	Try again.
DOCUMENT JAM	A document has jammed in the scanner document feeder	Remove the document jam.
DOOR OPEN	The side cover is not correctly latched	The side door and front door must be closed in the correct order. Open both doors. Close the front door first, then close the side door.
GROUP NOT AVAILABLE	You tried to select a group location where only a single location number can be used (for example, when you add locations for a multi-dial operation).	Try again. Check the location for the group.
LINE ERROR	Your unit cannot connect with the remote machine, or is disconnected because of a problem on the phone line.	Usually caused by a telephone line problem. Try again. If failure continues, wait an hour for the line to clear then try again
LOAD DOCUMENT	You tried to set up a sending operation with no document in the feeder.	Insert a document and try again.
MEMORY FULL	The memory is full.	Do one of these: A. Delete documents that are not necessary. B. Transmit again after more memory becomes available C. Divide the transmission into more than one operation.
NO ANSWER	The remote machine did not answer after all the redial attempts.	Try again. Make sure the remote machine is OK.

Trouble-shooting

<b>Error Message</b>	<b>Description</b>	<b>Solution</b>
NO. NOT ASSIGNED	The speed dial location you tried to use has no number stored in it.	Dial the number manually with the keypad, or store the number.
NO PAPER [ADD PAPER]	There is no paper in the paper cassette. Printing stops until paper is loaded.	Put paper in the paper cassette.
OVERHEAT	The printer has overheated.	Your unit will automatically return to the standby mode when it cools down to normal operating temperature. If failure continues, replace the fusing unit or the main PBA.
PAPER JAM 0 OPEN/CLOSE DOOR	Printing paper is jammed in paper feeding area or the pick-up unit	Press STOP and remove the jam.
PAPER JAM 1/2 OPEN/CLOSE DOOR	Printing paper is jammed in the machine main body or in the paper exit unit.	Remove the jam.
TONER LOW	The toner cartridge is almost empty, or toner particles are not equally applied in the cartridge	Remove the toner cartridge and carefully rock it from side to side. Try again. If problem continues, replace the cartridge.
TONER EMPTY	The toner cartridge is empty	Replace the toner cartridge.
DRUM WARNING	The OPC drum is almost at the end of its life (14,000 sides)	You have 1000 pages of print life left in the OPC Drum. Continue to use, or install a new OPC drum.
REPLACE DRUM	The OPC drum life is expired (15,000 sides)	Replace the OPC drum cartridge.
NO CARTRIDGE	A toner cartridge is not installed.	Install the cartridge.
BYPASS JAM	Paper feed problem from the bypass (Manual feed) Tray.	Open the side cover and remove the jam.
DUPLEX JAM	Paper feed problem in the duplex return path	Release the output feed lever and check the output area. Also, open the side door and check the duplex unit.
LINE BUSY	The remote fax didn't answer	Try again.
OPEN HEAT ERROR	No power to the fusing lamp	Check the thermostat, thermistor, fuser lamp and fuser connector and related wiring. Also check the 'Fuser On' signal from main PWA to Power Supply. Check the cable from Main PWA to Power Supply

<b>Error Message</b>	<b>Description</b>	<b>Solution</b>
Heating Error	During operation, Temperature does not go up	Check the thermistor contact point & the fusing lamp.
Scanner Locked	Scanner head does not move.	Check the transit lock. Check that the scanner cables are connected. Check the scanner home sensor, scanner motor or drive belt.

## 4.2 ABNORMAL IMAGE PRINTING AND DEFECTIVE ROLLERS

If an abnormal image occurs at regular intervals, check the parts shown below.

<b>NO</b>	<b>Roller</b>	<b>Abnormal image period</b>	<b>Kind of abnormal image</b>
1	OPC Drum	94.3 mm	White spot. Black spot
2	Charge Roller	37.7 mm	White spot. Black spot
3	Supply Roller	35.8 mm	Horizontal dark band
4	Develop Roller	44.8 mm	Horizontal dark band
5	Transfer Roller	57.8 mm	Contamination on reverse side of paper / transfer fault
6	Hot Roller	82.5 mm	Black spot, White spot
7	Pressure Roller	78.5 mm	Contamination on reverse side of paper

## 4.3 TROUBLESHOOTING

### 4.3.1 SCANNER

#### *COPY*

<b>Problem</b>	<b>Items to be checked</b>	<b>How to solve</b>
White copy	<ul style="list-style-type: none"> <li>• Make sure that the scanner cover is closed.</li> </ul>	<ul style="list-style-type: none"> <li>• Room lighting can go through thin paper. This causes quality problems</li> </ul>
	<ul style="list-style-type: none"> <li>• Check the shading profile</li> </ul>	<ul style="list-style-type: none"> <li>• Do the "Adjust Shading" procedure in Tech mode</li> </ul>
Black copy	<ul style="list-style-type: none"> <li>• Check the CCD problem in Main PBA.</li> </ul>	<ul style="list-style-type: none"> <li>• Check the CCD harness contact.</li> </ul>
	<ul style="list-style-type: none"> <li>• Check shading profile.</li> </ul>	<ul style="list-style-type: none"> <li>• Do the "Adjust Shading" procedure in Tech mode.</li> </ul>
Defective image quality	<ul style="list-style-type: none"> <li>• Check shading profile.</li> </ul>	<ul style="list-style-type: none"> <li>• Do the "Adjust Shading" procedure in Tech mode</li> </ul>
	<ul style="list-style-type: none"> <li>• Check the original is lying flat on the scanner glass.</li> </ul>	<ul style="list-style-type: none"> <li>• A gap above 0.5 mm can cause a blurred image.</li> </ul>
	<ul style="list-style-type: none"> <li>• Check the printing quality.</li> </ul>	<ul style="list-style-type: none"> <li>• See "Print" troubleshooting.</li> </ul>
Abnormal noise	<ul style="list-style-type: none"> <li>• Check the scanner drive mechanism.</li> </ul>	<ul style="list-style-type: none"> <li>• Check for mechanical problems in the scanner carriage, motor, gearbox, belt and belt tension spring.</li> <li>• Make sure that the scanner motor position is correct.</li> </ul>
	<ul style="list-style-type: none"> <li>• Check the Motor Driver chip on the Main PBA.</li> </ul>	<ul style="list-style-type: none"> <li>• If a driver is defective, replace the Main PBA.</li> </ul>

**PC-SCAN**



<b>Problem</b>	<b>Items to be Checked.</b>	<b>How to Solve</b>
Scanning Error	<ul style="list-style-type: none"> <li>• Check the printer cable is correctly installed.</li> </ul>	<ul style="list-style-type: none"> <li>• Use a standard IEEE1284 cable.</li> </ul>
	<ul style="list-style-type: none"> <li>• Check that the TWAIN driver is installed.</li> </ul>	<ul style="list-style-type: none"> <li>• Remove all other scanner drivers.</li> <li>• Reboot after you reinstall the TWAIN driver.</li> </ul>
	<ul style="list-style-type: none"> <li>• Check the printer port (Parallel) BIOS settings.</li> </ul>	<ul style="list-style-type: none"> <li>• Check the parallel port related items in the CMOS Setup. For a printer port, make sure that ECP is selected.</li> </ul>
	<ul style="list-style-type: none"> <li>• Check the harness connection.</li> </ul>	<ul style="list-style-type: none"> <li>• Check CN12 connection on the Main PBA</li> </ul>
	<ul style="list-style-type: none"> <li>• Check the IEEE1284 signal levels.</li> </ul>	<ul style="list-style-type: none"> <li>• If a signal level is defective, replace the Main PBA.</li> </ul>
	<ul style="list-style-type: none"> <li>• Check the USB signal level.</li> </ul>	<ul style="list-style-type: none"> <li>• If the USB signal level is defective, replace the Main PBA.</li> </ul>
Defective image Quality	<ul style="list-style-type: none"> <li>• Check shading profile.</li> </ul>	<ul style="list-style-type: none"> <li>• Do the “Adjust Shading” procedure in Tech mode.</li> </ul>
	<ul style="list-style-type: none"> <li>• Check the gap between original and scanner glass.</li> </ul>	<ul style="list-style-type: none"> <li>• A gap above 0.5 mm can cause a blurred image.</li> </ul>
Abnormal noise	<ul style="list-style-type: none"> <li>• Check the Scanner Motor and mechanical problems in the scanner.</li> </ul>	<ul style="list-style-type: none"> <li>• Check for mechanical problems in the scanner carriage, motor, gearbox, belt and belt tension spring.</li> <li>• Make sure that the scanner motor position is correct.</li> </ul>
	<ul style="list-style-type: none"> <li>• Check the motor driver in the Main PBA.</li> </ul>	<ul style="list-style-type: none"> <li>• If a driver is defective, replace the Main PBA.</li> </ul>

Trouble-shooting

**4.3.2 FAX****FAX/TELEPHONE PRECAUTIONS**

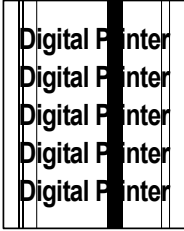
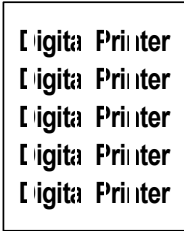

<b>Problem</b>	<b>Items to be Checked.</b>	<b>How to Solve</b>
TEL LINE CANNOT BE ENGAGED (NO DIAL TONE)	<ul style="list-style-type: none"> <li>• When you press the "OHD" key:               <ol style="list-style-type: none"> <li>a) Check the line cord connection.</li> <li>b) Check the MAIN LIU harness, and CN1 (LIU PBA).</li> <li>c) Check the relay operation of the LIU PBA: Is the control signal of CN18 (main) low?</li> </ol> </li> </ul>	<ol style="list-style-type: none"> <li>a) Insert it correctly into the connection jack called "Line".</li> <li>b) Replace defective parts.</li> <li>c) Replace the main PBA IF the control signal of N18 (main) is high.</li> </ol> Replace the LIU PBA if high but the phone line cannot be connected.
Tone dial is not possible	<ul style="list-style-type: none"> <li>• Check CN18 (main PBA), MAIN-LIU harness, and CN1 (LIU PBA)</li> </ul>	<ul style="list-style-type: none"> <li>• Replace defective parts.</li> </ul>
Tone dial is possible but not pulse dial	<ul style="list-style-type: none"> <li>• Check DP control signal of CN18-11 of MAIN PBA and the circuit around R15. U6 and Q2 of Liu PBA.</li> </ul>	<ul style="list-style-type: none"> <li>• Replace the LIU PBA.</li> </ul>
Defective fax transmission	<ul style="list-style-type: none"> <li>• Check CN18 (main PBA), MAIN LIU harness, and CN1 (LIU PBA).</li> <li>• Is the external phone off hook?</li> <li>• Check 'hook off' : Refer to 'TEL LINE CANNOT BE ENGAGED' above.</li> <li>• Check the transmission path: Check output of CN20-3.4 and T2-4(LIU PBA).</li> <li>• Check the reception path: Check output CN1-1 (LIU PBA) and input of CN18-1 (main PBA).</li> </ul>	<ul style="list-style-type: none"> <li>• Replace defective parts.</li> <li>• Replace the LIU PBA if low.</li> <li>• Refer to 'TEL LINE CANNOT BE ENGAGED' above.</li> <li>• Replace the main PBA, if abnormal.</li> <li>• Replace the LIU PBA if CN1-1(LIU PBA) is not confirmed.</li> <li>• Replace the main PBA if CN20-1(MAIN PBA) is not confirmed.</li> </ul>
Defective automatic fax reception	<ul style="list-style-type: none"> <li>• Is the ring detected? Check the ring signal at CN1-9 (LIU PBA).</li> <li>• Refer to "Defective Transmission".</li> </ul>	<ul style="list-style-type: none"> <li>• Replace the LIU PBA if it cannot be checked.</li> <li>• Refer to "Defective Transmission".</li> </ul>

### 4.3.3 PRINT QUALITY

Error Status	Check	Solution
<p><b>Vertical black line and band</b></p>  <p>B174T920.WMF</p>	<ol style="list-style-type: none"> <li>Faulty toner cartridge</li> <li>LSU</li> </ol>	<ol style="list-style-type: none"> <li>Change the toner cartridge</li> <li>Replace LSU</li> </ol>
<p><b>Vertical white line</b></p>  <p>B174T921.WMF</p>	<ol style="list-style-type: none"> <li>LSU window dirty</li> <li>Toner cartridge</li> </ol>	<ol style="list-style-type: none"> <li>Clean the LSU window</li> <li>If not the LSU, change the toner cartridge.</li> </ol>
<p><b>No image</b></p>  <p>B174T922.WMF</p>	<ol style="list-style-type: none"> <li>Is the seal tape removed?</li> <li>OPC is properly grounded?</li> <li>LSU running well?</li> <li>Toner low?</li> <li>Is there video data from the Main PBA?</li> </ol>	<ol style="list-style-type: none"> <li>Check and remove tape</li> <li>Measure the resistance between frame ground and the OPC ground spring attached to the frame. Confirm good ground. If faulty, check the ground path through the frame.</li> <li>Replace the LSU</li> <li>Shake the toner cartridge and print. If an image appears, the toner cartridge is empty</li> <li>Print the engine test pattern. If no pattern is printed, replace the Main PBA.</li> </ol>
<p><b>Light image</b></p>  <p>B174T923.WMF</p>	<ol style="list-style-type: none"> <li>Is the seal tape removed?</li> <li>LSU light power normal?</li> <li>Enough toner?</li> <li>High charger voltage?</li> <li>Lower bias voltage</li> <li>Transfer voltage and roller.</li> <li>Contamination of high voltage contact.</li> </ol>	<ol style="list-style-type: none"> <li>Check and remove tape</li> <li>Checking LSU light power is difficult. Compare with a new one.</li> <li>Check the toner counter</li> <li>~6. Change the HVPS (SMPS) Board.</li> <li>Clean or replace the transfer roller.</li> <li>Stray toner can increase contact resistance and cause a bad contact. Clean the contaminated area.</li> </ol>

Trouble-shooting

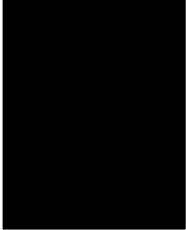

Error Status	Check	Solution
<b>Dark image</b>  B174T924.WMF	<ol style="list-style-type: none"> <li>1. LSU light power normal?</li> <li>2. Video data is always supplied?</li> </ol>	<ol style="list-style-type: none"> <li>1. Checking LSU light power is difficult. Compare with a new one.</li> <li>2. Replace defective board(s)</li> </ol>
<b>Background</b>  B174T925.WMF	<ol style="list-style-type: none"> <li>1. High voltage output is normal?</li> <li>2. C/R of toner cartridge is dirty?</li> </ol>	<ol style="list-style-type: none"> <li>1. Change the HVPS (SMPS) Board.</li> <li>2. Replace the toner cartridge.</li> </ol>
<b>Ghost</b>  B174T926.WMF	<ol style="list-style-type: none"> <li>1. High voltage output.</li> <li>2. Quenching Lamp.</li> <li>3. Bad high voltage contact.</li> </ol>	<ol style="list-style-type: none"> <li>1. Change the HVPS Board.</li> <li>2. Check the quenching lamp comes on – replace the quenching lamp if necessary.</li> <li>3. Clean inside the machine or replace the toner cartridge.</li> </ol>
<b>Stains on back of paper</b>	<ol style="list-style-type: none"> <li>1. Dirty transfer roller.</li> <li>2. Toner debris in the paper path</li> <li>3. Pressure roller dirty</li> </ol>	<ol style="list-style-type: none"> <li>1. Clean the transfer roller with a vacuum cleaner.</li> <li>2. Clean the paper path with a cloth or air brush.</li> <li>3. Replace the fusing unit</li> </ol>
<b>Poor Fusing</b>	<ol style="list-style-type: none"> <li>1. Paper quality and finish?</li> <li>2. Check the fusing unit temperature.</li> <li>3. The machine was kept at a low temperature for a long time?</li> </ol>	<ol style="list-style-type: none"> <li>1. Should use recommended paper.</li> <li>2. Measure the thermistor voltage to the Main PBA. It is 2.3V±5% when printing is correct. If not, replace the fusing unit.</li> <li>3. Re-check after you let the machine come up to room temperature.</li> </ol>
<b>Partial blank image (not periodic)</b>	<ol style="list-style-type: none"> <li>1. Toner is low?</li> <li>2. The toner cartridge is out of position?</li> </ol>	<ol style="list-style-type: none"> <li>1. Replace the toner cartridge.</li> <li>2. Check and adjust.</li> </ol>

Error Status	Check	Solution
<p><b>Partial blank image (periodic)</b></p>	<ol style="list-style-type: none"> <li>1. Developer roller scar or particle. (45 mm)</li> <li>2. OPC scar or particle. (95 mm)</li> <li>3. Transfer roller scar or particle. (58 mm)</li> </ol>	<ol style="list-style-type: none"> <li>1. Replace the toner cartridge.</li> <li>2. Replace the drum cartridge.</li> <li>3. Replace the transfer roller.</li> </ol>
<p><b>Different image density (left and right)</b></p> <div style="border: 1px solid black; padding: 5px; margin: 10px 0;"> <p>Digital Printer Digital Printer Digital Printer Digital Printer Digital Printer</p> </div> <p style="font-size: small;">B174T929.WMF</p>	<ol style="list-style-type: none"> <li>1. Charge roller's pressure not balanced</li> <li>2. Dev. roller and OPC or Dev. roller and blade's pressure not balanced</li> <li>3. Transfer roller's pressure not balanced on each side</li> </ol>	<ol style="list-style-type: none"> <li>1. Replace the drum cartridge.</li> <li>2. Replace the drum and/or toner cartridge.</li> <li>3. Check the left and right springs of the transfer roller and the spring that pushes the development unit inside the machine</li> </ol>
<p><b>Horizontal band</b></p> <div style="border: 1px solid black; padding: 5px; margin: 10px 0;"> <p><del>Digital Printer</del> Digital Printer Digital Printer <del>Digital Printer</del> <del>Digital Printer</del></p> </div> <p style="font-size: small;">B174T928A.WMF</p>	<ol style="list-style-type: none"> <li>1. Unstable high voltage contact</li> <li>2. Charge roller dirty</li> <li>3. Dirty hot roller</li> <li>4. Malfunction of LSU</li> </ol>	<ol style="list-style-type: none"> <li>1. Clean each contact and check good contact</li> <li>2. Clean the charge roller.</li> <li>3. Replace the fusing unit</li> <li>4. Check the Main PBA</li> </ol>

Trouble-shooting

**No Image**

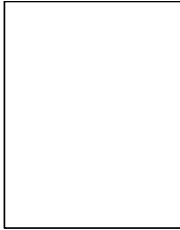

B174T922.WMF

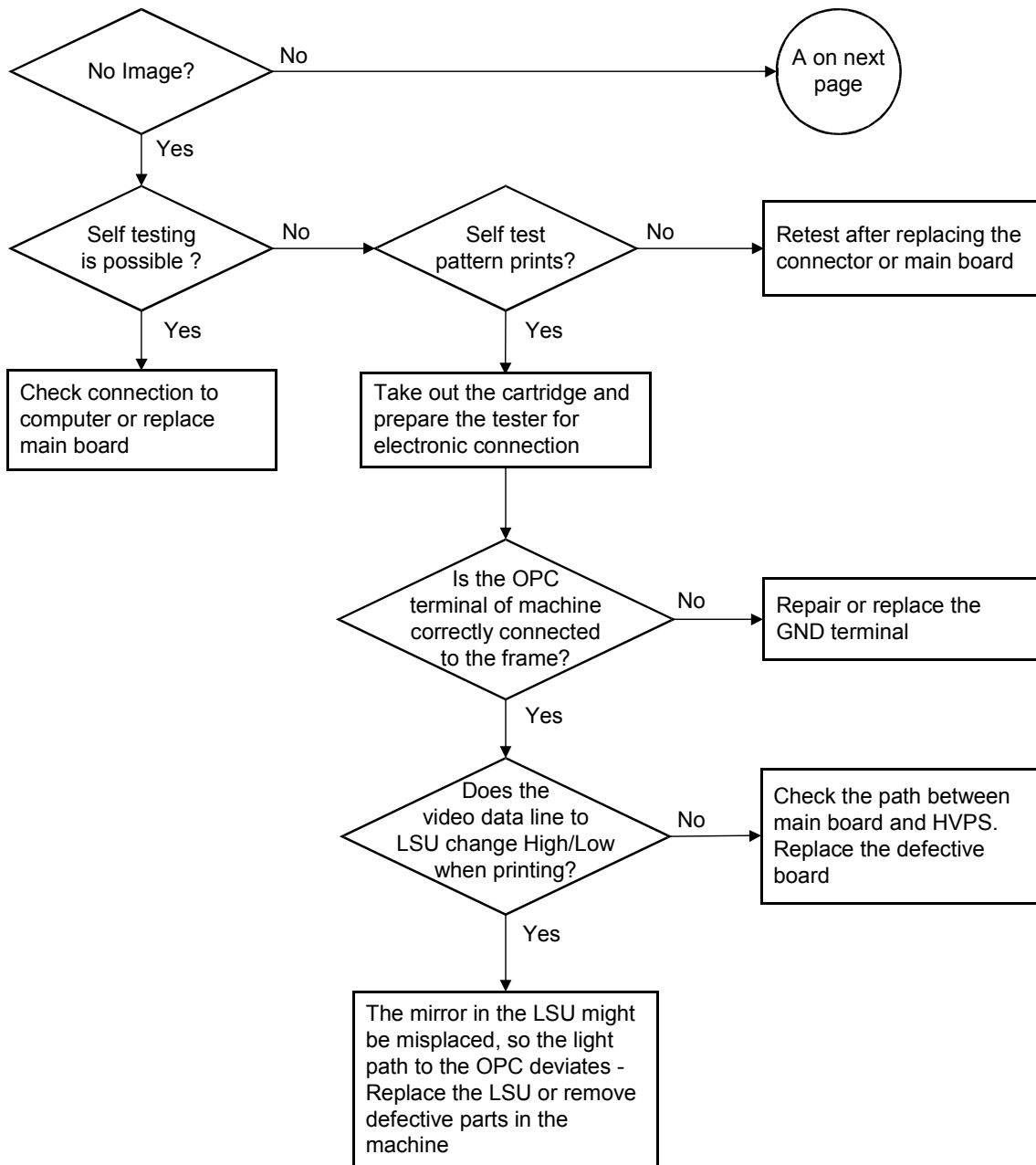

B174T901.WMF

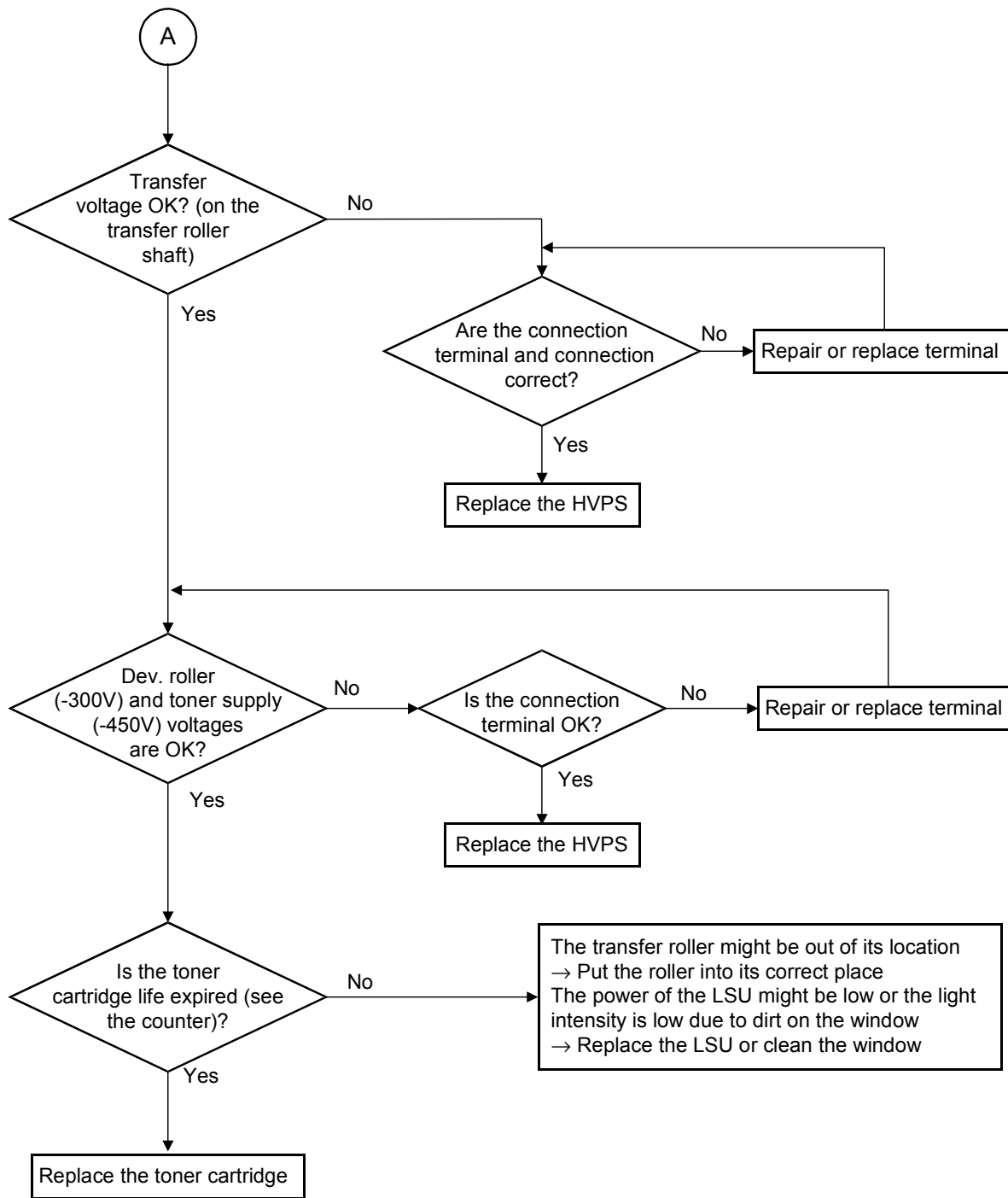

Trouble-shooting

**All Black**

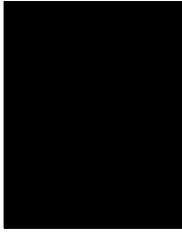

B174T924.WMF

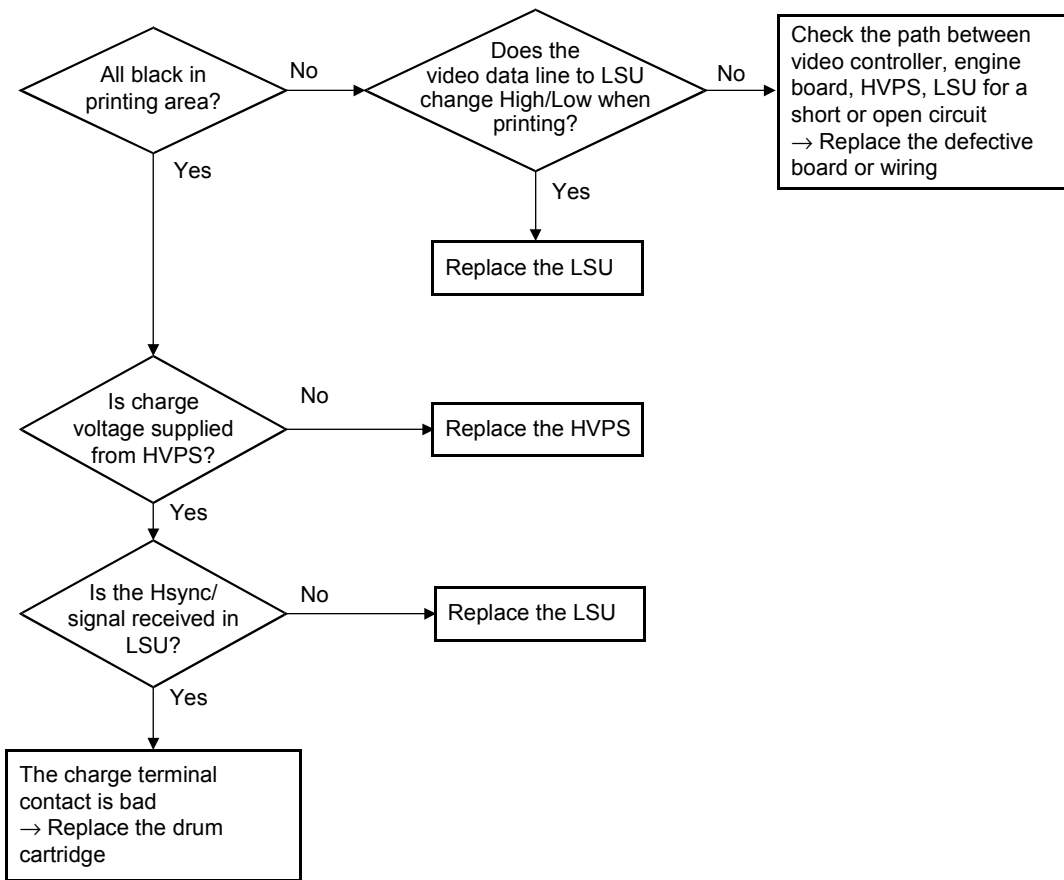

B174T903.WMF

### Vertical White Line (Band)



B174T921.WMF

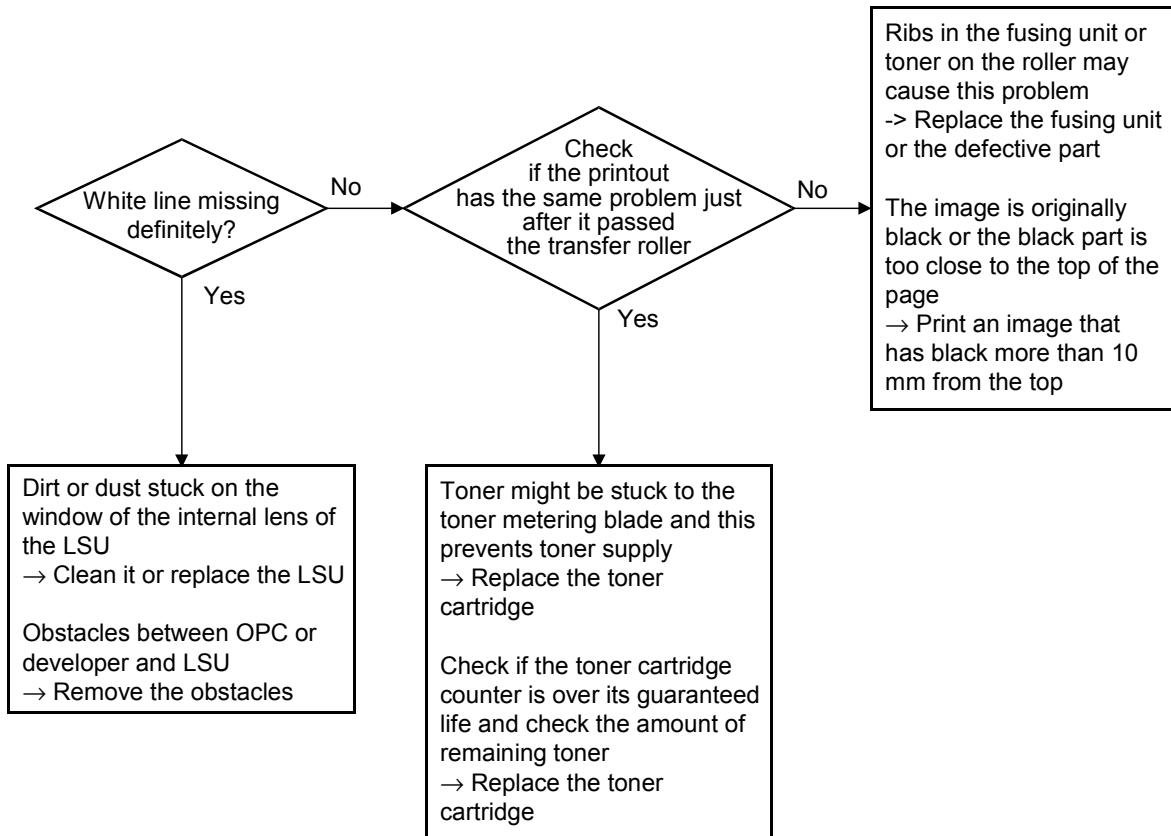

Trouble-shooting

B174T904.WMF

**Dark Image**

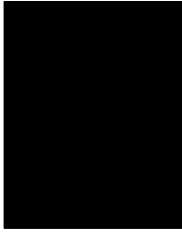

B174T924.WMF

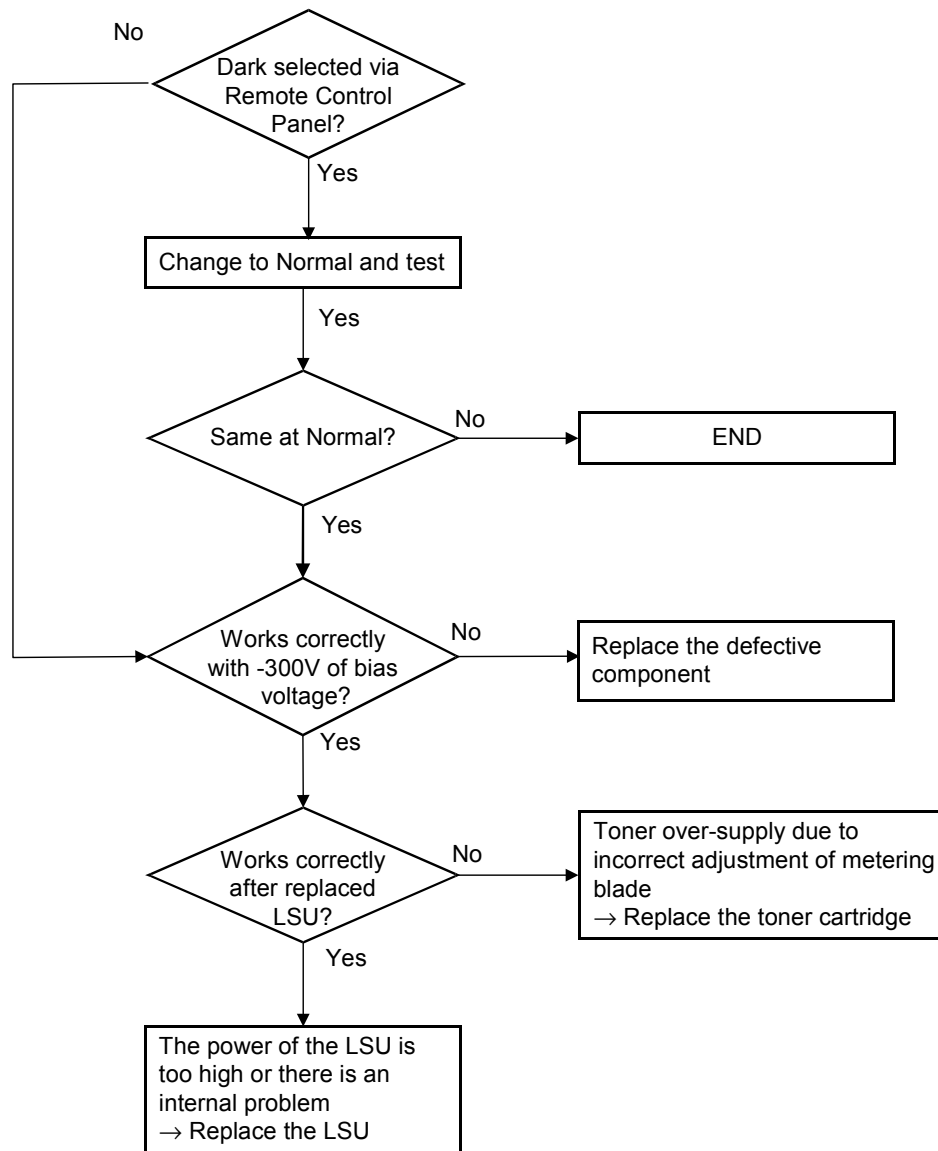

B174T905.WMF

**Background**

Digital Printer  
Digital Printer  
Digital Printer  
Digital Printer  
Digital Printer

B174T925.WMF

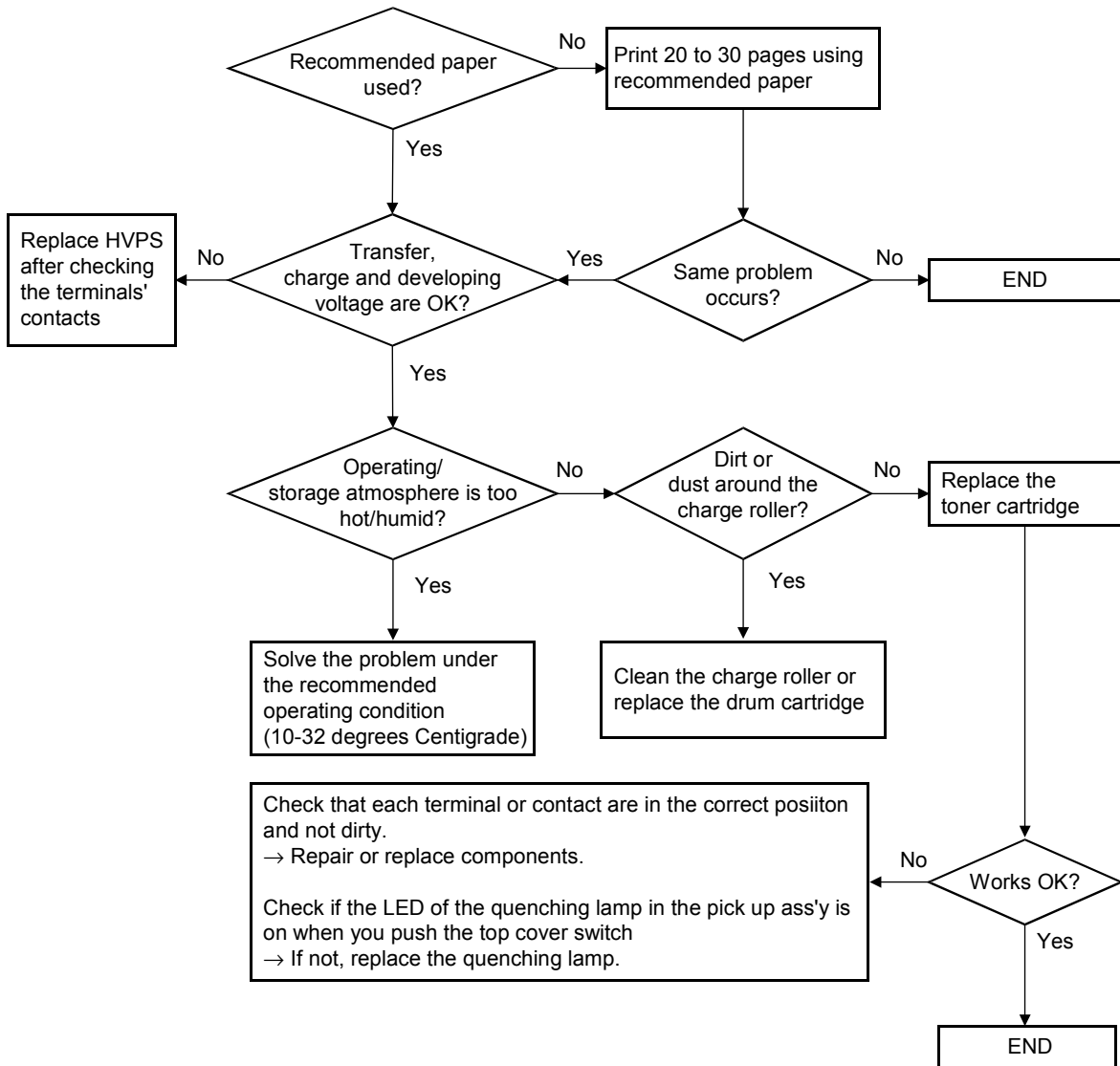

Trouble-shooting

B174T906.WMF



Ghost



B174T926.WMF

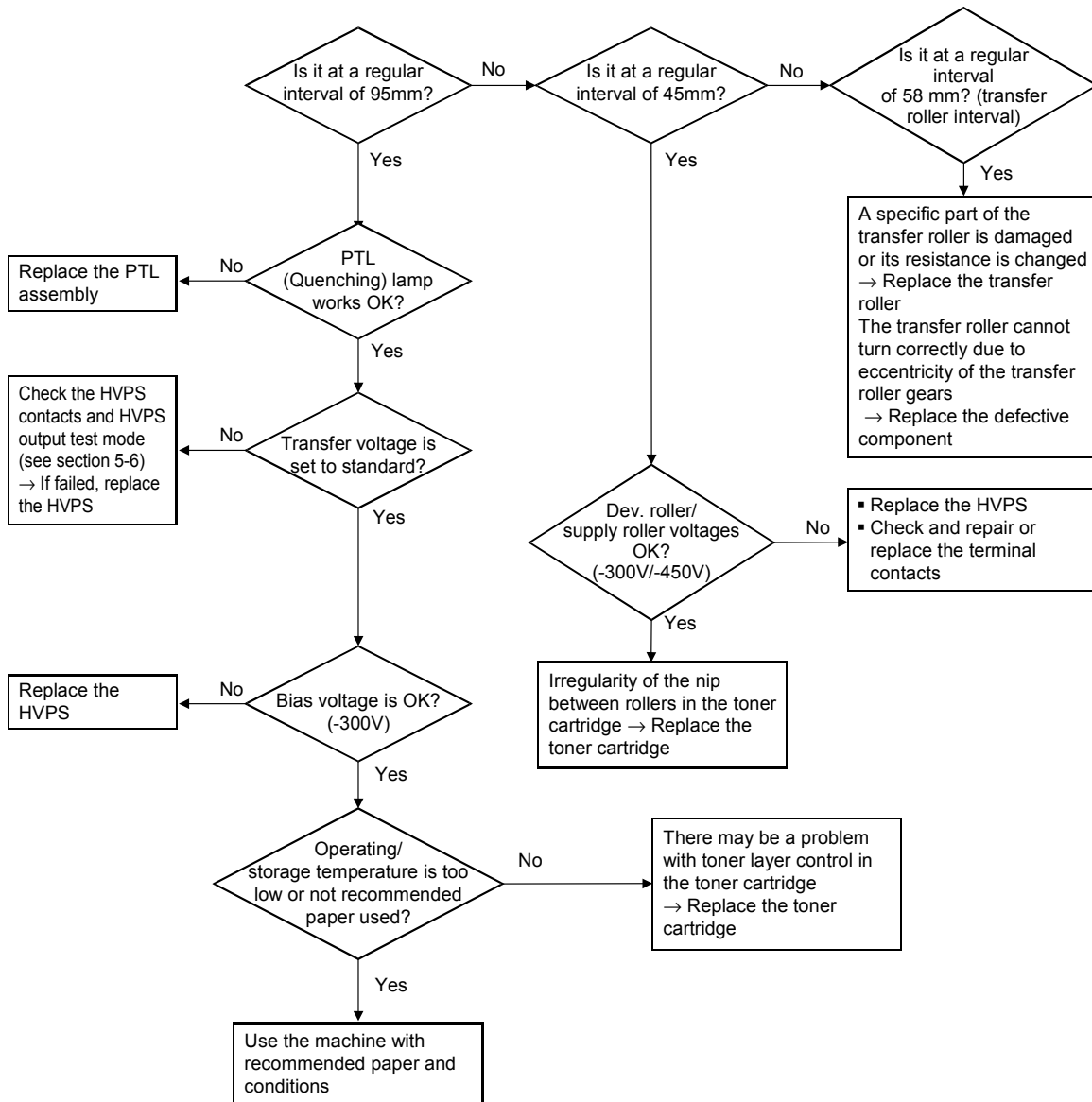

B174T907.WMF

### Black Spot



B174T927.WMF

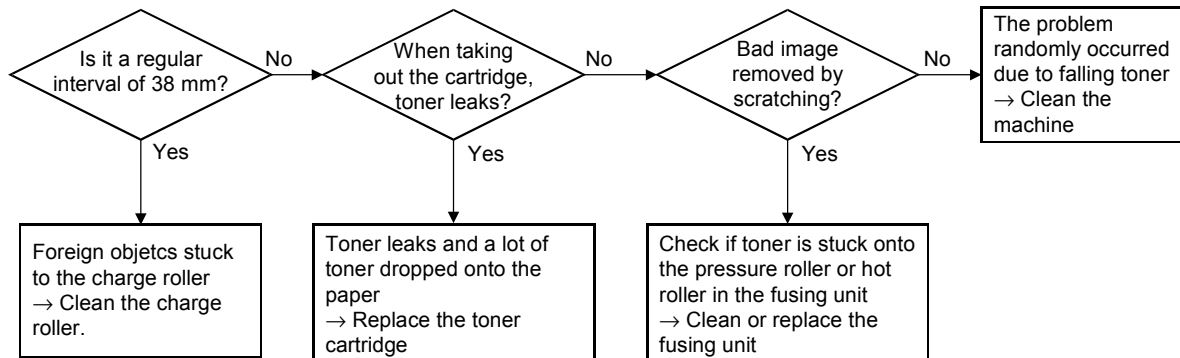

B174T908.WMF



**Horizontal Band**

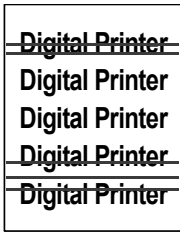

B174T928A.WMF



B174T928B.WMF

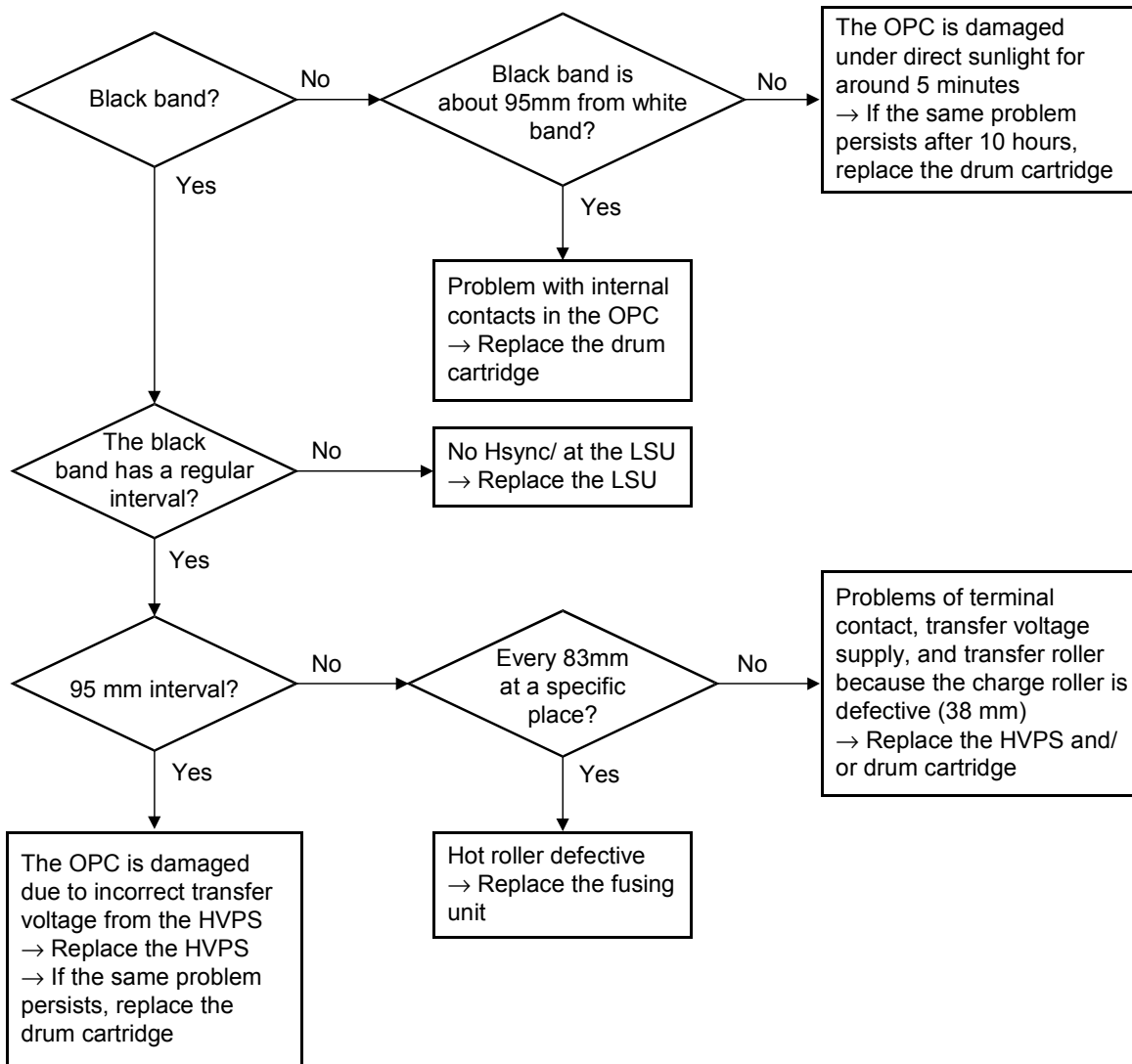

B174T909.WMF

### Irregular Density



B174T929.WMF

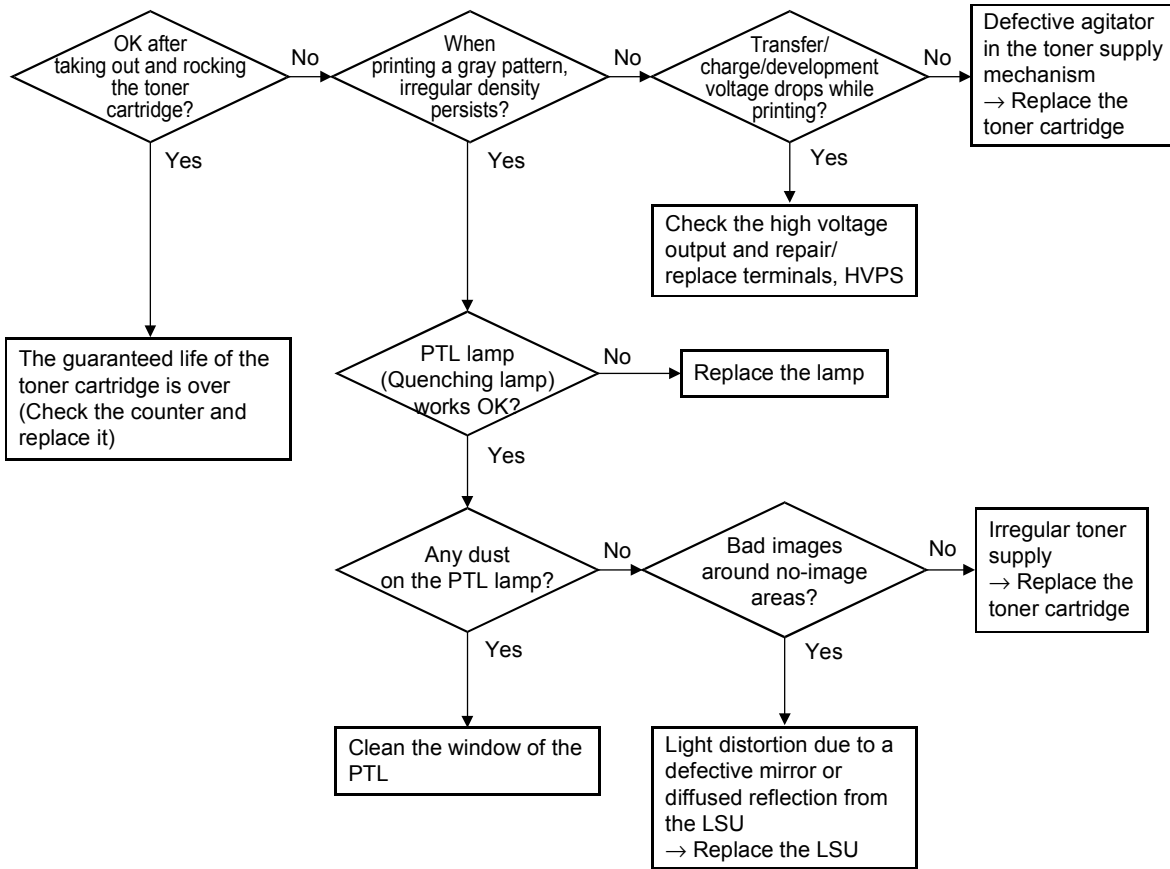

B174T910.WMF

Trouble-shooting

**White Spot**

Digital Printer  
Digital Printer  
Digital Printer  
Digital Printer  
Digital Printer

B174T930.WMF

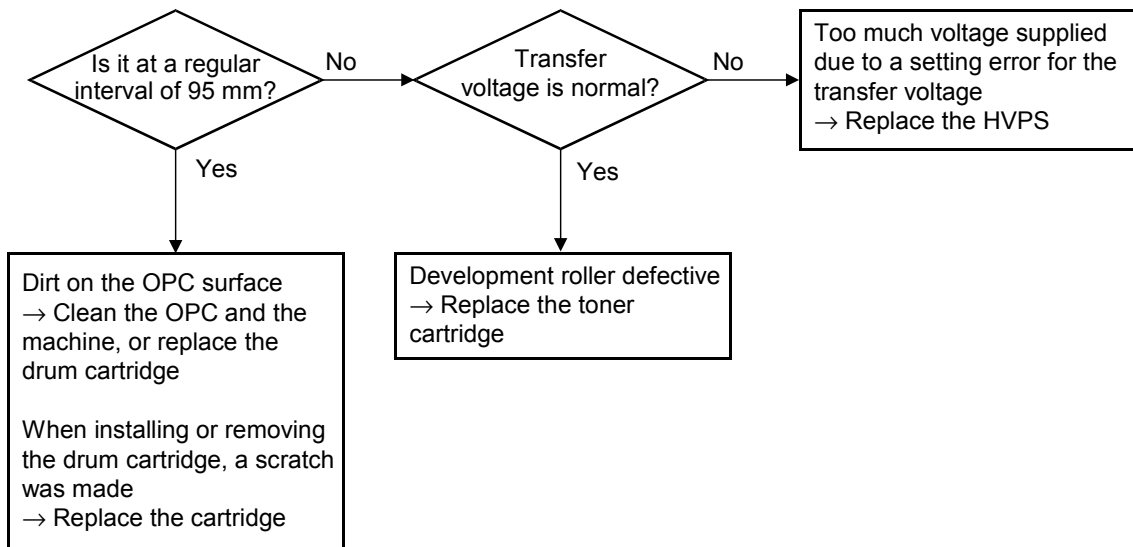

B174T911.WMF

### Trembling at the End When OHP Printing

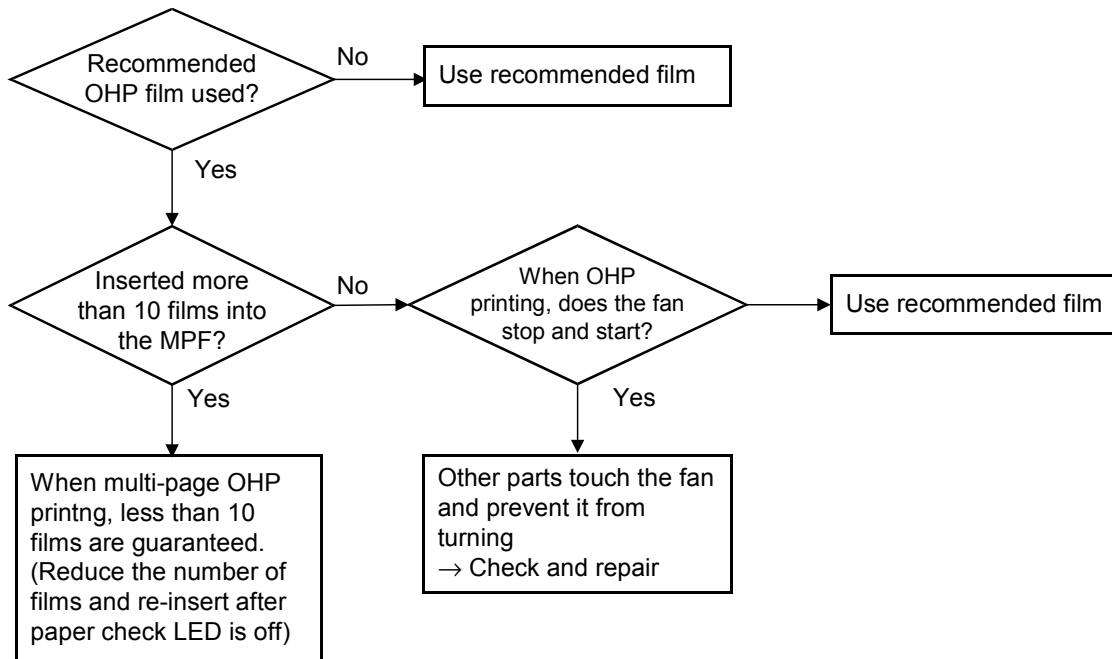

B174T912.WMF



**Poor Fusing Grade**

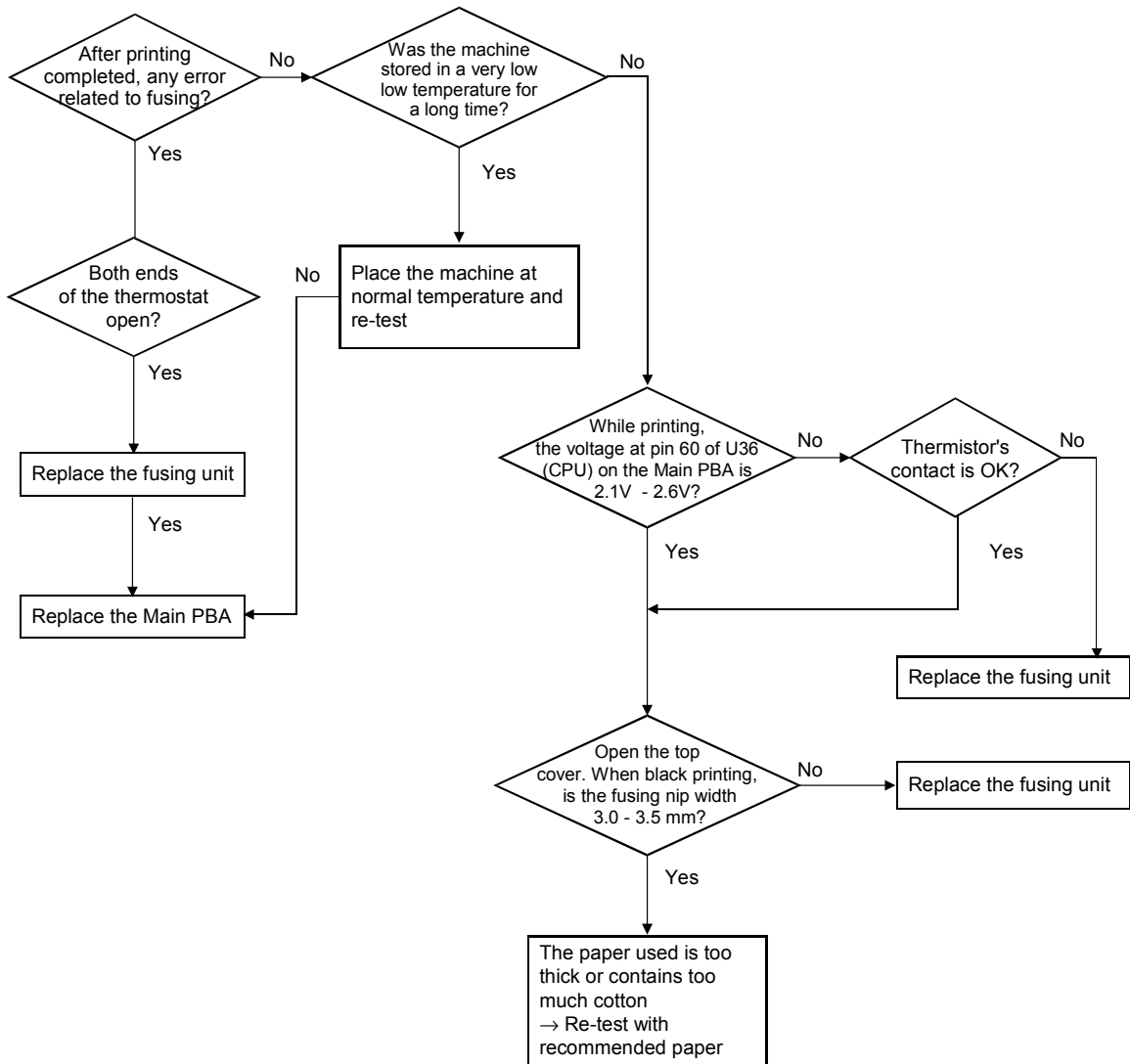

B174T913.WMF

### 4.3.4 MALFUNCTION

Error Status	Check	Solution
No power	<ol style="list-style-type: none"> <li>1. Check the supplied power</li> <li>2. Check if fuse F1 on the SMPS is open</li> </ol>	<ol style="list-style-type: none"> <li>1. If the supplied power differs from machine's power rating, replace the machine to the correct type for your area.</li> <li>2. Replace SMPS.</li> </ol>
Fuser Error	<ol style="list-style-type: none"> <li>1. Thermostat open</li> <li>2. AC wire open</li> <li>3. Thermistor wire open</li> <li>4. Main PBA</li> </ol>	<ol style="list-style-type: none"> <li>1. Detach the AC connector and measure the resistance between pin 1 and 2. If it is mega-ohm, the thermostat is open, Replace it.</li> <li>2. Check if there is a bad connector contact or if the wire is cut.</li> <li>3. Check the thermistor wire and its connection.</li> <li>4. Replace the Main PBA</li> </ol>
Cover open	<ol style="list-style-type: none"> <li>1. When you close the side cover, check that the lever is pressed</li> <li>2. Microswitch contact</li> <li>3. CPU and related circuit</li> </ol>	<ol style="list-style-type: none"> <li>1. Open the side cover and press the lever with a pen. If the machine detects that the cover is closed, there is a mechanical problem with the side cover and lever assembly. If not, there is an electrical problem.</li> <li>2. Check and replace the microswitch</li> <li>3. Check and replace the main PBA</li> </ol>
Jam 0	<p>Check where Jam 0 occurs</p> <ol style="list-style-type: none"> <li>1. Paper is not picked up</li> <li>2. Paper is at the feed sensor</li> <li>3. Occurred when inserting specific types of paper such as envelopes into the bypass tray?</li> <li>4. Occurred when inserting specific types of paper such as envelopes into the bypass tray?</li> <li>5. Is the Stacker Extender folded out?</li> <li>6. Does the guide bend the sheets?</li> </ol>	<ol style="list-style-type: none"> <li>1. Check whether the solenoid is working or not by using Engine test mode</li> <li>2. Check for a feed sensor malfunction.</li> <li>3. Re-try inserting fewer sheets. <ul style="list-style-type: none"> <li>• Fan the sheets and align them</li> <li>• Take out the loaded sheets and insert them in the reverse direction</li> </ul> </li> <li>4. Take out the loaded sheets and insert them in the reverse direction <ul style="list-style-type: none"> <li>• Inserted sheets as recommended for Manual Feeding?</li> <li>• When loading, tap the sheets until the paper sensor detects them in the tray</li> </ul> </li> <li>5. When using long paper, use the Stacker Extender</li> <li>6. Adjust the guide to fit the paper width</li> </ol>

Trouble-shooting



Error Status	Check	Solution
Jam 1	Paper is stopped just after the fusing unit.	<ol style="list-style-type: none"> <li>1. It is mostly caused by double feeding. Check that paper is stocked correctly in the feeder.</li> <li>2. Check the feed actuator position and actuator's operation. There may be stiff moving or double reflection. If not, check the operation of the feed sensor with Engine test mode.</li> <li>3. Check the exit lever operation. Remove the jam and check the actuator motion by hand. If the actuator is too stiff, paper is wrapped around the heat roller. Remove obstacles or replace.</li> </ol>
Jam 2	Check where Jam 2 occurs <ol style="list-style-type: none"> <li>1. Paper is curled and cannot exit.</li> <li>2. Paper is curled in the exit cover?.</li> </ol>	<ol style="list-style-type: none"> <li>1. Remove paper and check if the hot roller strippers are defective. Clean the fusing unit.</li> <li>2. Check that the lock works well. Watch whether the ribs of the exit cover have a burr or resistive edge. If they do, remove obstacles or replace.</li> </ol>
Jam 2 at face-down tray	<ol style="list-style-type: none"> <li>1. The paper is not drawn in because of the stack of papers in the exit tray.</li> <li>2. Does it curl while coming out?</li> </ol>	<ol style="list-style-type: none"> <li>1. Load the recommended quantity of paper</li> <li>2. Open the Front Cover and check whether a roller or spring, which is related to paper exit, is not out of position. If so, re-locate or replace.</li> </ol>
Clutch error	<ol style="list-style-type: none"> <li>1. Check the spring of the solenoid</li> <li>2. Check the armature assembly/cushion</li> <li>3. Electrical check</li> </ol>	<ol style="list-style-type: none"> <li>1. Check whether the spring is stretched or not.</li> <li>2. Check that the armature is correctly installed.</li> <li>3. Remove the Main PBA.</li> </ol>
High voltage error	<ol style="list-style-type: none"> <li>1. Check the terminal output voltage</li> <li>2. Check HVPS</li> </ol>	<ol style="list-style-type: none"> <li>1. Remove the toner cartridge and open the cover. Then press the cover open switch lever and measure the voltage with a high voltage probe, and send a print job. If the voltage is normal, change the toner cartridge.</li> <li>2. Disassemble and check output voltage of the HVPS and replace it.</li> </ol>
Feeding obstacles	Does the plate-knock up prevent the paper loading?	MP Tray: Turn the power off and on. Open and close the side cover to return to the original state. Cassette : Adjust the guide to fit the paper width.
Skew	Is the guide set to the paper width?	Adjust the guide to fit the paper width

<b>Error Status</b>	<b>Check</b>	<b>Solution</b>
Stacking	<ol style="list-style-type: none"> <li>1. Did the user take out the stacker extender to support long paper?</li> <li>2. Stacked more paper than the stacker can hold?</li> </ol>	<ol style="list-style-type: none"> <li>1. Use the extender for long paper</li> <li>2. The face-up stacker normally can hold 100 pages when using 75 g/m<sup>2</sup> paper. But, stacking capacity can be lower for some types of paper.</li> </ol>
Engine Error	Check Harness_CN7. (Main PBA to LSU)	Refer to the troubleshooting flow chart "ENGINE ERROR".
Document Jam	Document is not picked up (in the ADF).	<ol style="list-style-type: none"> <li>1. Check that documents are correctly stacked in the ADF.</li> <li>2. Check whether documents were fastened together with staples or clips.</li> <li>3. Load the recommended quantity of paper.</li> </ol>
	Document is stopped after it has fed into the ADF.	<ol style="list-style-type: none"> <li>1. Check whether the REG sensor is working or not.</li> <li>2. Check whether the Feed Roller is working or not.</li> </ol>
	Does it curl while coming out?	<ol style="list-style-type: none"> <li>1. Check if the ADF Upper Cover is closed properly.</li> <li>2. Check that the ADF ass'y is assembled correctly.</li> </ol>

**No Power (LCD NO display LED Off)**

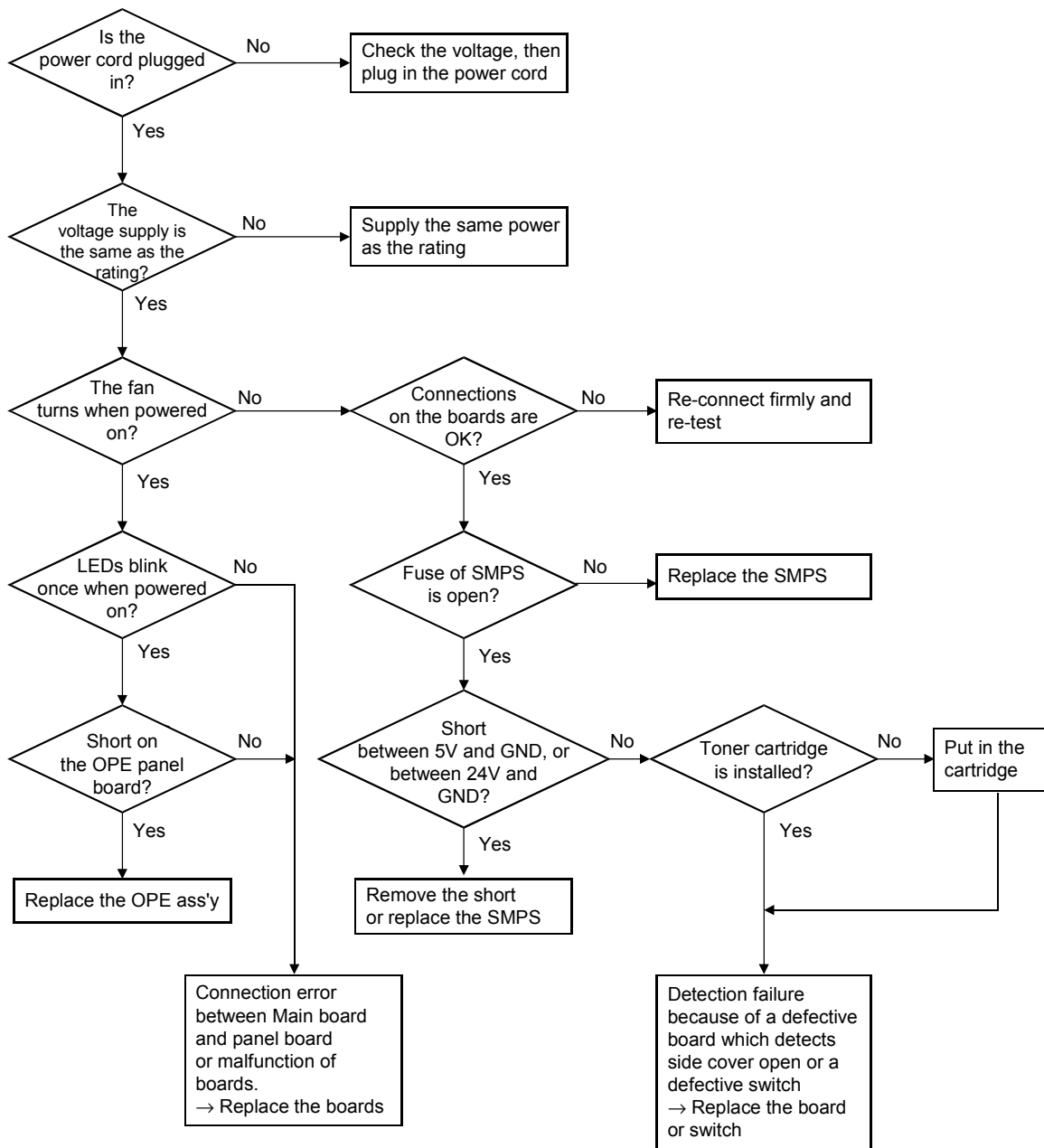

B174T914.WMF

### Fuser Error

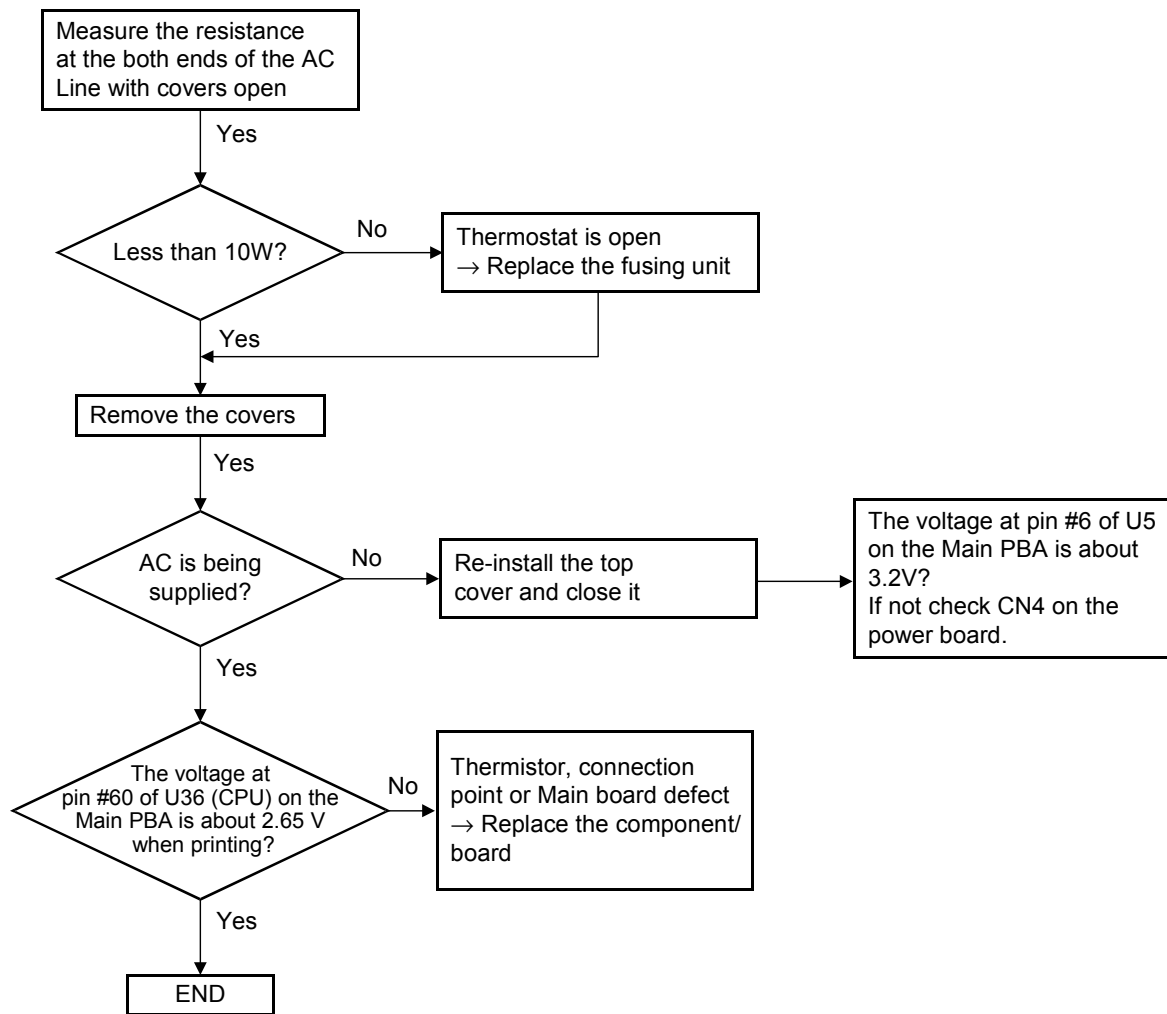

Trouble-shooting

**Paper Jam (Mis-Feeding)**

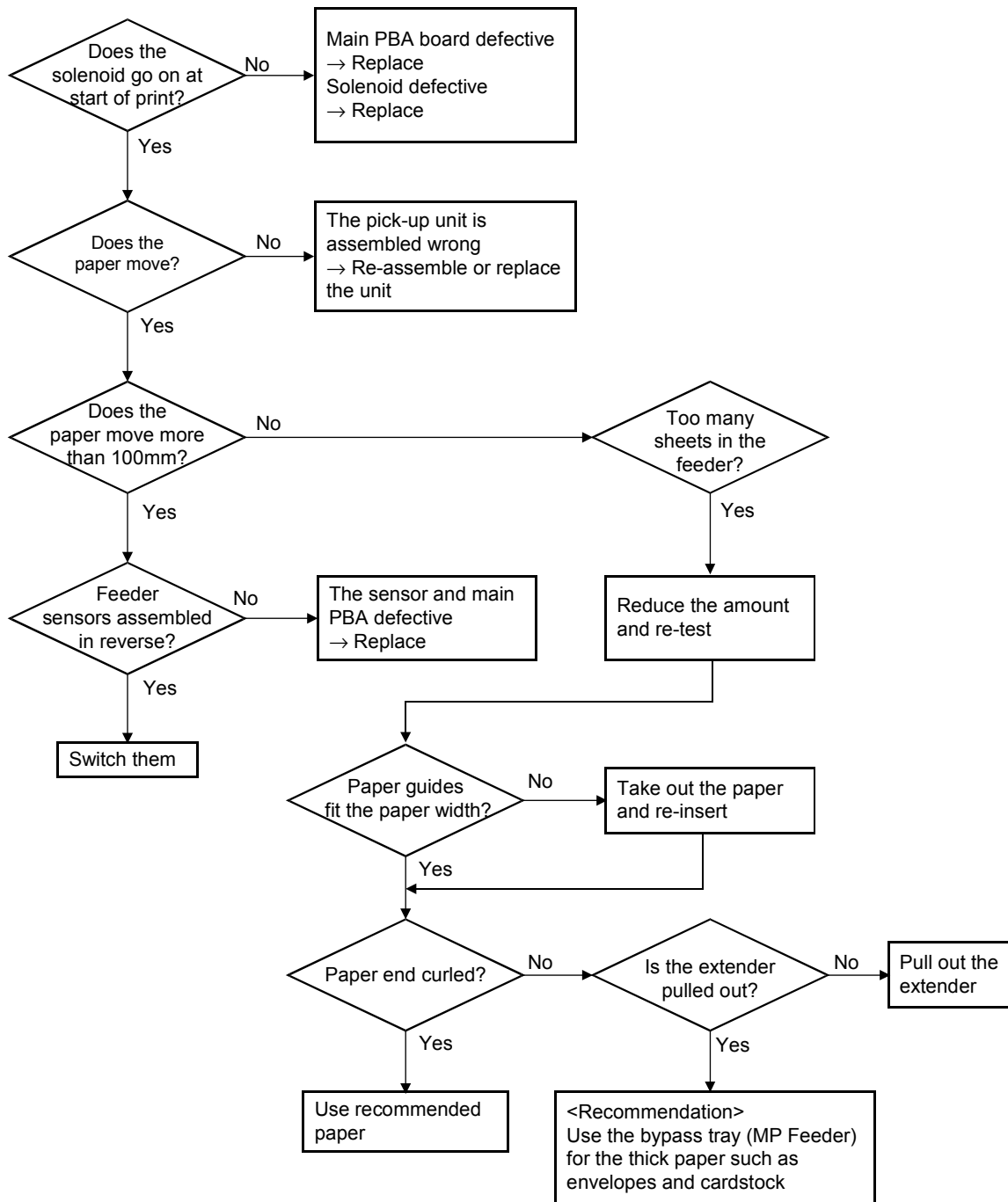

B174T916.WMF

**Paper Jam (Jam 1)**

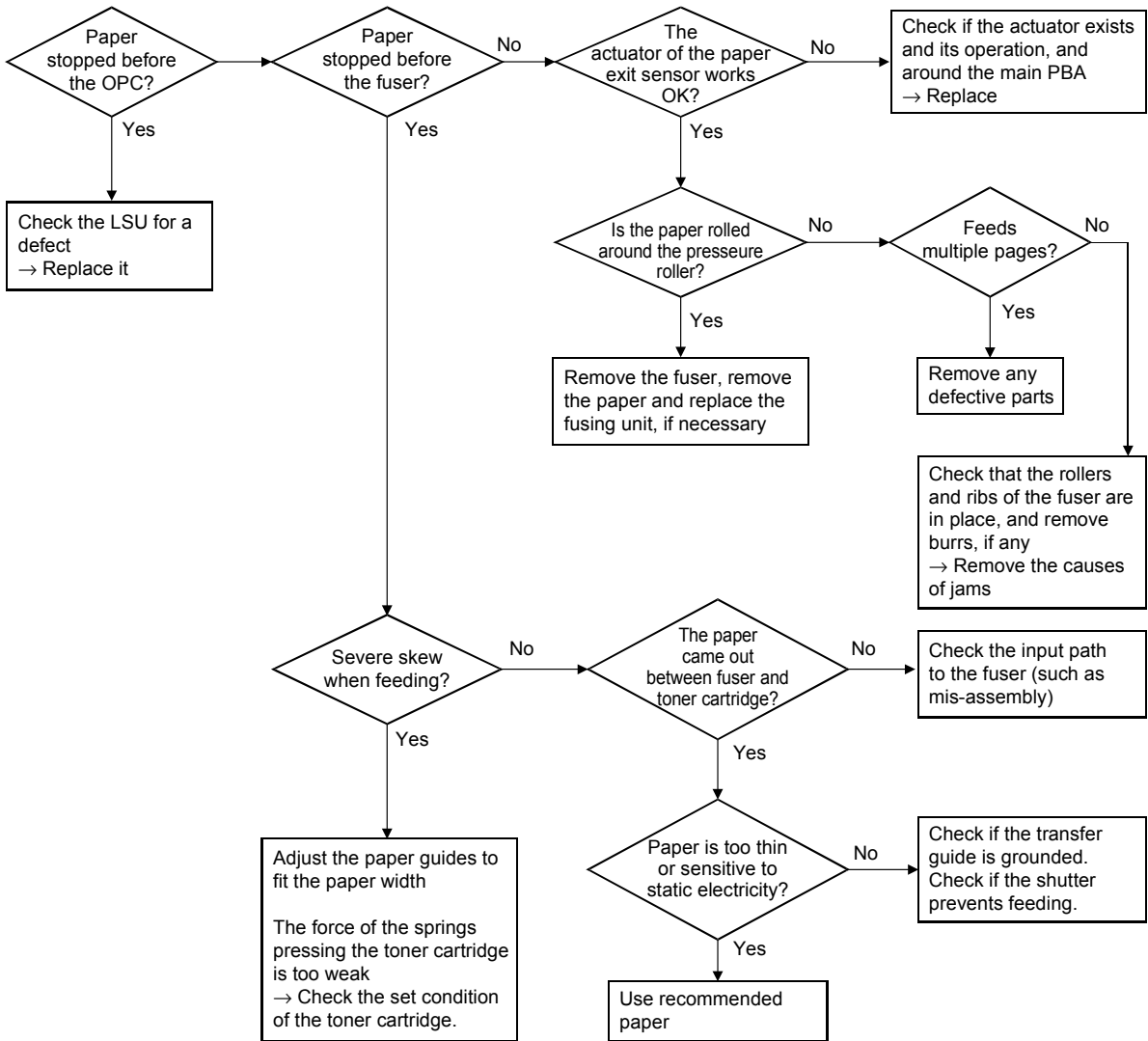

Trouble-shooting

B174T917.WMF

**Engine Error**

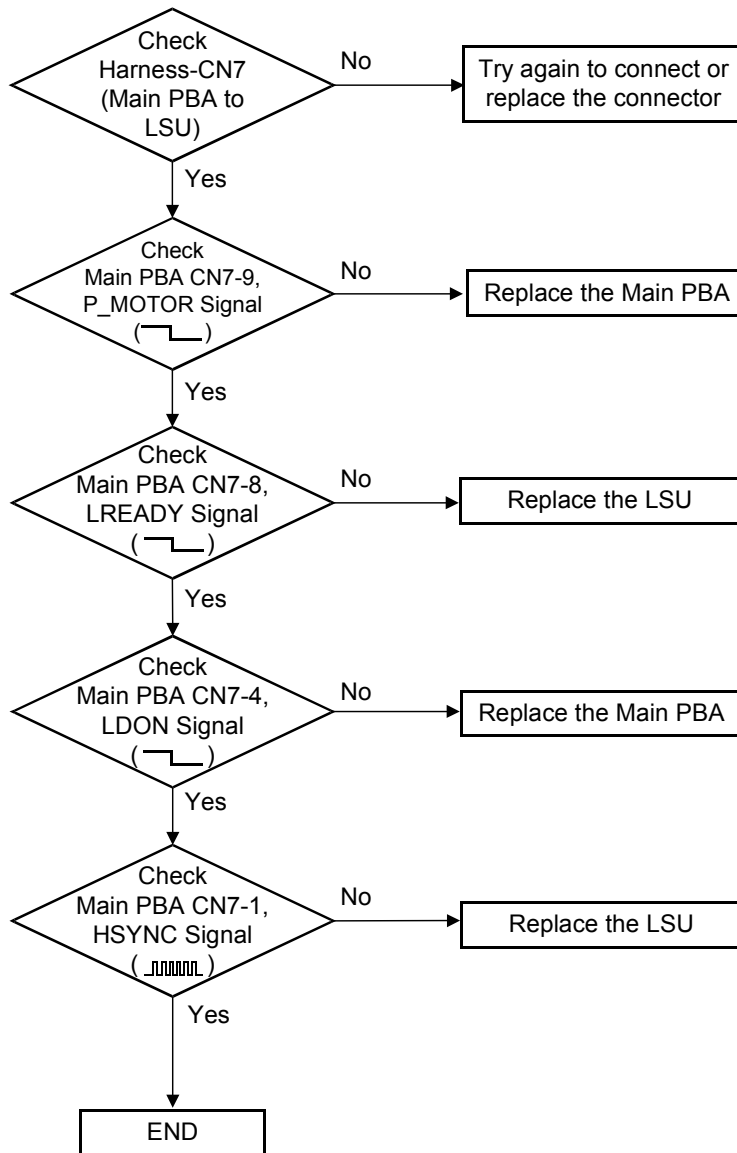

B174T918.WMF

### **4.3.5 TONER CARTRIDGE AND DRUM CARTRIDGE SERVICE**

#### ***Precautions on Safe-keeping of the Drum Cartridge***

Excessive exposure to direct light for more than a few minutes may cause damage to the cartridge.

#### ***Service for the Life of Toner Cartridge***

If the printed image is light due to the life of the toner cartridge, you can temporarily improve the print quality by redistributing the toner (shake the toner cartridge). But, you should replace the toner cartridge to solve the problem completely.



**Symptoms of a defective toner cartridge**

Fault	Signs	Cause & Check	Solution
<p>Light image and partially blank image (The life is ended.)</p> <div style="border: 1px solid black; padding: 2px; width: fit-content;"> <p>Digital Printer Digital Printer Digital Printer Digital Printer Digital Printer</p> </div> <p>B174T923.WMF</p>	<ul style="list-style-type: none"> <li>• The printed image is light or dirty and untidy.</li> <li>• Some part of the image is not printed.</li> <li>• Periodically a "tick tick" noise occurs.</li> </ul>	<ol style="list-style-type: none"> <li>1. If the printed image is light or dirty and untidy– Shake the toner cartridge and then recheck.               <ol style="list-style-type: none"> <li>1) NG: Check the weight of the toner cartridge</li> <li>2) OK: Lack of toner, so the life is nearly ended.</li> </ol> </li> <li>2. Some part of image is not printed - Shake the toner cartridge and then recheck.               <ol style="list-style-type: none"> <li>1) NG: Check the weight of the toner cartridge and clean the LSU window with a cotton swab, then recheck.</li> <li>2) OK: Lack of toner, so the life is nearly ended.</li> </ol> </li> <li>3. Periodically a "tick tick" noise occurs - Measure the cycle and the weight of the toner cartridge.</li> <li>4. White vertical stripes on the whole image or part of the image : Check the weight of the toner cartridge.</li> </ol>	<ol style="list-style-type: none"> <li>1. For symptoms 1, 2, and 3 If it becomes better after shaking, replace with a new toner cartridge after 50-100 sheets if the life of the cartridge is almost ended.</li> <li>2. If it becomes better after cleaning the LSU window, then the toner cartridge is normal. (Because of a foreign substance on the LSU window, part of the image was not printed.)</li> <li>3. If the cycle of the noise is about 2 seconds, the toner inside the toner cartridge has almost ended. (Install a new toner cartridge after making about 200 more sheets)</li> <li>4. This is caused by lack of toner, so replace with a new toner cartridge.</li> </ol>
<p>Toner contamination</p>	<ul style="list-style-type: none"> <li>• Toner falls on the paper periodically.</li> <li>• Contaminated with toner on prints partly or over the whole surface.</li> </ul>	<ol style="list-style-type: none"> <li>1. Toner falls on the paper periodically.               <ol style="list-style-type: none"> <li>1) Check the cycle of occurrence.</li> </ol> <p>Check the appearance of both ends of the OPC drum.</p> </li> <li>2. The center of the printed matter is contaminated with toner.               <ol style="list-style-type: none"> <li>1) Check whether foreign substances or toner are stuck to the terminal (contact point) of the toner cartridge.</li> <li>2) Check whether the state of the terminal assembly is normal.</li> </ol> </li> </ol>	<ol style="list-style-type: none"> <li>1. If both ends of the OPC drum are contaminated with toner: Replace the toner cartridge if it is near the end of its life.</li> <li>2. Is the customer using recycled toner?</li> </ol>

Fault	Signs	Cause & Check	Solution
<p>White Black spot</p>  <p>B174T927.WMF</p>	<ul style="list-style-type: none"> <li>• Light or dark black dots on the image occur periodically</li> <li>• White spots occur in the image periodically</li> </ul>	<ol style="list-style-type: none"> <li>1. If light or dark periodical black dots occur, this is because the rollers are contaminated with a foreign substance or paper particles.                         <ol style="list-style-type: none"> <li>1) 37.7 mm interval : Charge roller</li> <li>2) 94.3 mm interval : OPC drum</li> </ol> </li> <li>2. If white spots occur in a black image at intervals of 94.3 mm, or black spots occur elsewhere, the OPC drum is damaged or a foreign substance is stuck to the surface.</li> </ol>	<ol style="list-style-type: none"> <li>1. Run OPC Cleaning Mode Print (User Tools – 12. Maintenance – Clean Drum) 4-5 times repeatedly to remove. Especially check for foreign substances on the OPC surface, then remove them with a clean gauze moistened with Isopropyl Alcohol if necessary. <b>Caution:</b> Never use normal (ethyl) alcohol.</li> <li>2. If they do not disappear after you run OPC Cleaning Mode Print (User Tools – 12. Maintenance – Clean Drum) 4-5 times.                         <ul style="list-style-type: none"> <li>: at intervals of 94.3mm - Replace the OPC Drum.</li> <li>: at intervals of 37.7mm - Remove the foreign substance, Clean the Charge Roller</li> <li>: Broken image - Replace the toner cartridge.</li> </ul> </li> </ol>
<p>Recycled product</p>	<ul style="list-style-type: none"> <li>• Poor appearance of the toner cartridge.</li> <li>• Dirty and rough printouts.</li> <li>• Bad background in the image.</li> </ul>	<ol style="list-style-type: none"> <li>1. Poor appearance of the toner cartridge.                         <ol style="list-style-type: none"> <li>1) Check if there is the damage to the label and if different materials are used.</li> <li>2) Check the appearance of parts of the toner cartridge, such as frame, hopper.</li> </ol> </li> <li>2. Dirty and rough printouts.                         <ol style="list-style-type: none"> <li>1) Check whether foreign substances or toner are stuck to the terminal (contact point) of the toner cartridge.</li> <li>2) Check whether the state of the terminal assembly is normal.</li> </ol> </li> </ol>	<ol style="list-style-type: none"> <li>1.                         <ol style="list-style-type: none"> <li>1) Look for evidence of disassembling the toner cartridge.</li> <li>2) Check if materials other than normal parts of the toner cartridge are added or substituted.</li> </ol> </li> <li>2. If the toner cartridge appears to be disassembled (see 1 above)                         <ol style="list-style-type: none"> <li>1) It occurs when the toner cartridge is recycled more than 2 times.</li> <li>2) If toner that is nearly expired is collected to use, it is considered to be recycled.</li> </ol> </li> </ol>

Trouble-shooting

Fault	Signs	Cause & Check	Solution
Ghost & Image Contamination	<ul style="list-style-type: none"> <li>• The printed image is too light or dark, or partially contaminated with black.</li> <li>• Totally contaminated with black. (Black image printed out)</li> </ul>	<ol style="list-style-type: none"> <li>1. The printed image is too light or dark, or partially contaminated with black.               <ol style="list-style-type: none"> <li>1) Check whether foreign substance or toner are stuck to the terminal (point of contact) of the toner cartridge.</li> <li>2) Check whether the terminal assembly is normal.</li> </ol> </li> </ol>	<ol style="list-style-type: none"> <li>1. All of 1, 2 above               <ol style="list-style-type: none"> <li>1) Remove toner and foreign substances adhered to the contact point of the toner cartridge.</li> <li>2) The contact point of the unit facing the contact point of the toner cartridge must also be cleaned.</li> <li>3) If the terminal assembly is unsafe:                   <ul style="list-style-type: none"> <li>• Fully attach the terminal or reassemble it after disassembling.</li> <li>• Disassemble the side plate and push the terminal to be attached, then reassemble it.</li> </ul> </li> </ol> </li> </ol>
		<ol style="list-style-type: none"> <li>2. Totally contaminated with black. (Black image printed out)               <ol style="list-style-type: none"> <li>1) Check whether foreign substances are stuck to the terminal (point of contact) of the toner cartridge and the state of assembly. (Especially check the charge roller terminal.)</li> </ol> </li> </ol>	<ol style="list-style-type: none"> <li>2. The OPC drum is not electrically charged. Clean the terminals of the charge roller, then recheck it.</li> </ol>

### 4.3.6 PROBLEMS CAUSED BY SOFTWARE

***The printer is not working (1)***

**Description:** While power is on, the printer is not working in the printing mode.

<b>Check and Cause</b>	<b>Solution</b>
1. Check if the PC and the printer are properly connected and the toner cartridge installed.	1. Replace the printer cable. If the problem is not solved after the cable is replaced, check the amount of remaining toner.
2. Printing is not working in Windows.	2. Check if the connection between PC and printer port is correct. If you use Windows, check if the printer driver is set up. If the printer driver is properly set up, check if program that is used for printing is working. The best way to find out is to open the memo pad to check the function of printing. If it is not working in a certain program, adjust the setup that the program requires. Sometimes, the printout is normal within the Windows basic programs, but it's not working in a particular program. In such case, install the new driver again. If not working in a Windows basic program, check that the setup of the parallel port in CMOS is for ECP.
3. Check if the printer cable is directly connected to a peripheral device	3. If the scanner needs to be connected to the printer, first the remove the scanner from the PC to see if the printer is working alone.

Trouble-shooting

***The printer is not working (2)*****Description:**

After receiving the printing command, no response at all or low speed of printing occurs due to wrong setup of the environment rather than a malfunction of the printer itself.

<b>Check and Cause</b>	<b>Solution</b>
1. Secure more space on the computer hard disk.	1. Not working, with the message "insufficient printer memory" means that there is a hard disk space problem rather than a RAM problem. In this case, provide more space on the computer hard disk. Secure more space using a disk utilities program.
2. Printing error occurs even if there is enough space in the hard disk.	2. The connection of the cable and printer port is not correct. Check if the connection is properly done and if the parallel port in CMOS is properly set up.
3. Check the parallel-port-related items in the CMOS Setup.	3. As a printer port, Select ECP or SPP. SPP normal mode supports 8-bit data transfer, while ECP Mode transfers 12-bit data.
4. Reboot the system to print.	4. If the regular font is not printing, the cable or the printer driver may be defective. Turn the PC and printer off, and reboot the system to print again. If the problem is not solved, double-click the printer in My Computer and check if the driver version is correct. If the problem still occurs, replace the cable.

**Abnormal Printing****Description:**

Printing is not working properly even when the cable has no problem. (even after the cable is replaced). If the printer won't work at all or strange characters are printed, the printer driver may be defective or CMOS Setup may be incorrect.

<b>Check and Cause</b>	<b>Solution</b>
1. Set up the parallel port in the CMOS SETUP.	1. Select SPP (Normal) or ECP
2. Printer Driver Error.	2. Check the printer in My Computer (to see if the printer driver version is correct; if not, install the new driver)
3. Error message due to insufficient memory. (The printing job sometimes stops due to insufficient virtual memory, but it is actually because of insufficient space on the hard disk.)	3. Delete unnecessary files to secure enough space on the hard disk, and start printing job again.

## Spooling Error

### Description:

'Spool' stands for "simultaneous peripheral operations online". To 'spool' a computer document or task list (or "job") is to read it in and store it, usually on a hard disk or larger storage medium so that it can be printed or otherwise processed at a more convenient time (for example, when a printer is finished printing its current document).

Check and Cause	Solution
1. Insufficient space on the hard disk in the directory assigned for the basic spool.	1. Delete unnecessary files to provide more space to start the printing job.
2. If the previous printing error is not solved.	2. If there are some files with the extension ****.jnl, delete them and reboot Windows. Then restart the printing job.
3. When expected to collide with another program.	3. Shut down all other programs except the current one, if possible.
4. When an application program or the printer driver is damaged.	4. Delete the printer driver completely and reinstall it.
5. When some files related to the OS are damaged or virus infected.	5. After rebooting the computer, check for viruses, restore the damaged files and reinstall the program to do the printing job.
6. Memory is less than the suggested amount.	6. Install sufficient memory in the PC.

### How to delete data using the spool manager

In the spool manager, the installed drivers and the list of the documents waiting to be printed are shown. Select the document to be deleted and check the delete menu. If you intend to delete the current document being printed, the data being transferred to the printer will be output and then the document is removed. Before choosing the document, the menu is still inactive. Or take the document out of the list and repeat the routine as above or finish the spool manager.

## 5. SERVICE TABLES

### 5.1 USER MODE

This table shows the settings and functions available in the User Mode. These are described in the User Guide. The table is given here to show settings that the user possibly changed.

Function	Item	Contents
01. SYSTEM DATA	CASSETTE PAPER	LETTER / A4 / LEGAL
	BYPASS PAPER	LETTER / A4 / LEGAL
	MESSAGE CONF.	ON / OFF / ERROR
	AUTO JOURNAL	ON / OFF
	RECEIVE CODE	0-9
	POWER SAVE	ON / OFF
	ECM MODE	ON / OFF
	RX REDUCTION	ON / OFF
	DISCARD SIZE	0-30mm
	REDIAL INTERVAL	1-15
	REDIALS	1-13
	ANSWER ON RING	1-7
	SEND FROM MEMORY	ON / OFF
	LOCAL ID	ON / OFF
CLOCK MODE	12 / 24 HOUR	
02. SYSTEM ID	FAX / ID	FAX No. (CSI) / ID (TTI)
03. DATE & TIME		Set date and time
04. SYSTEM SETUP	PREFIX DIAL NO.	Enter number
	SECURE RECEIVE	On / OFF / PRINT
	RINGER VOLUME	LOW ~ HIGH (10 steps)
	ALARM SOUND	ON / OFF
	KEY SOUND	ON / OFF
	SPEAKER CONTROL	COM / ON / OFF
	SELECT LANGUAGE	English / French / Spanish / Portuguese
	USB MODE	FAST / SLOW
	FAX DUPLEX	OFF / LONG EDGE / SHORT EDGE
	IMAGE QUALITY	NORMAL / TEXT / IMAGE
	SCAN SLEEP MODE	Off / 4 hours / 8 hours / 12 hours
	HOME SET	CONTRAST (Light ~ Dark : 5 steps) / IMAGE (TEXT / MIXED / PHOTO)
05. MEMORY CLEAR	SYSTEM ID	
	SYSTEM DATA	
	PHONE BOOK / MEMORY	
	TX-RX JOURNAL	
06. DELAY TX		Enter number
07. MEMORY TX		Enter number
08. PRIORITY TX		Enter number and name



Function	Item	Contents
09. POLLING	TX PLOLL / DELAY RX POLL	Enter code and Bulletin on/off / Enter number and time
10. ADD/CANCEL	ADD / CANCEL	Add number / Cancel number
11. GROUP DIAL	NEW / EDIT	Create and edit group dial
12. MAINTENANCE	CLEAN DRUM	Perform drum cleaning
	NEW DRUM	YES / NO
	NOTIFY TONER LOW	Customer No.
		Customer Name
		Service No.
Serial No.		
REMOTE TEST	ON / OFF	
14. TX CONFIRM	Message Confirmation Report	
15. SCHEDULE JOB	Schedule Information List	
16. PHONE BOOK	Phone Book	
17. SYSTEM LIST	System Data List	
18. TX JOURNAL	Transmission Journal	
19. RX JOURNAL	Reception Journal	
20. HELP LIST	Help List	

## 5.2 TECH MODE

### 5.2.1 HOW TO ENTER SERVICE MODE

The technician can examine the machine and do different tests in service (tech) mode. This will help show the cause of a malfunction.

The machine operates correctly in Tech mode.

Do this procedure to go into the Tech mode:

Menu → # → 1 → 9 → 3 → 4 in sequence.

The LCD shows "T". Then the machine goes into service (tech) mode.

While in Tech mode, the machine continues to do all normal operations.

Do this procedure to go back to user mode:

Menu → # → 1 → 9 → 3 → 4

Or turn the power off, then on.

### 5.2.2 SETTING UP THE SYSTEM IN TECH MODE

Function	Item	Contents
01. SYSTEM DATA	DIAL MODE	TONE / PULSE
	MODEM SPEED	33.6 / 28.8 / 14.4 / 12.0 / 9.6 / 4.8 (K bps)
	ERROR RATE	5% / 10%
	SET TX LEVEL	09-15
	SILENCE TIME	12 sec. / Unlimit / OFF
02. SYSTEM ID	The same as User Mode	☛ 5.1
03. DATE & TIME	The same as User Mode	
04. SYSTEM SETUP	The same as User Mode	See Note, ☛ 5.1
05. MEMORY CLEAR	CLEAR ALL MEMORY	Select country code
06. DELAY TX	The same as User Mode	☛ 5.1
07. MEMORY TX	The same as User Mode	
08. PRIORITY TX	The same as User Mode	
09. POLLING	The same as User Mode	
10. ADD/CANCEL	The same as User Mode	
11. GROUP DIAL	The same as User Mode	

**Note:** You can also see these extra features on the LCD in Tech Mode only.

\* ID\_COPY [On] / [Off]

\* AUTO POSITION [X] / [Y]

These features are not available on this model at this time. Do not change these settings. Otherwise, the machine may not work correctly.

Function	Item	Contents	
12. MAINTENANCE	CLEAN DRUM	Perform drum cleaning	
	NEW DRUM	YSE / NO	
	NOTIFY TONER LOW	Customer No.	
		Customer Name	
		Service No.	
		Serial No.	
	SWITCH TEST		
	MODEM TEST		
	SRAM TEST	OK / NG	
	DRAM TEST	OK / NG	
	ROM TEST	FLASH / ENGINE versions	
	PATTERN TEST	PATTERN1-7, QAPATTERN1-4, ALL "PATTERN 1-7"	
	CLEAR COUNT Enter Password (1934 enter)	TOTAL PAGE COUNT	
		Clear CRU PRINTS COUNT	
		Clear FLT SCAN (Platen mode) COUNT	
		Clear ADF SCAN COUNT	
		Clear USED DRUM COUNT	
		Clear USED TONER COUNT	
	ANSWER ON CNG	1-4	
	ADJUST SHADING	(☛ 5.2.5)	
FLASH UPGRADE	LOCAL / REMOTE (☛ 5.2.5, 5.4)		
PROGRAM DIAL	SET / PRINT (☛ 5.2.5)		
	- Enter No.		
	- ECM on/off		
	- Select Error rate		
	- Select Coding		
	- Select Modem speed		
	- Adjust Tx level		
REMOTE TEST	ON / OFF		
14. TX CONFIRM	MSG. CONFIRM	Message Confirmation Report	
15. SCHEDULE JOB	SCHEDULE JOB	Schedule Information List	
16. PHONE BOOK	PHONE BOOK	Phone Book	
17. SYSTEM LIST	SYSTEM DATA	System Data List	
18. TX JOURNAL	TRANSMISSION	Transmission Journal	
19. RX JOURNAL	RECEPTION	Reception Journal	
20. HELP LIST	HELP LIST	Help List	
	PROTOCOL	PROTOCOL DUMP LIST	
	ERROR CODE	ERROR CODE REPORT	

## 5.2.3 SYSTEM DATA

### ***DIALING MODE***

Select the dialing mode to agree with the user's type of line.

- TONE: Dialing using tones
- PULSE: Dialing using pulses

### ***MODEM SPEED***

You can set the maximum modem speed.

During call setup, the baud rate is automatically adjusted to agree with the slowest device. Keep the default at 33.6 Kbps.

Only adjust this where the local line conditions are extremely poor.

### ***ERROR RATE***

The baud rate automatically goes to 2400 bps when the error rate is not the same as the set value. This keeps the error rate below the set value.

You can set the rate between 5% and 10%.

### ***SET TX LEVEL***

You can set the level of the transmission signal. The Tx level must be less than -12 dBm.

**CAUTION:** The send fax level is set at the factory. Do not change this in the field.

### ***SILENCE TIME***

In ANS/FAX mode, after a call is picked up by the answering machine, the machine monitors the line. If a period of silence is detected on the line, the machine processes the incoming call as a fax message and the machine begins to receive. You can select a silence detection time between limited (about 12 seconds) and unlimited time.

When "12 sec" is selected, the machine switches to receive mode immediately after it detects a period of silence. When "unlimited" is selected, the machine does nothing until the answering operation is completed (this also occurs when a period of silence is detected). After the answering operation is completed, the machine switches to receiving mode.

## 5.2.4 MEMORY CLEAR

### ***CLEAR ALL MEMORY***

Use this function to reset the system to the defaults that were set at the factory.

This function resets the system to the initial values when the machine does not work correctly. Values are set to the default values. The machine will not keep data set by the user. This procedure does not clear the counter data values.

#### **Procedure**

1. Set the [CLEAR ALL MEMORY] in tech mode from 05. Memory Clear.
2. Press the ENTER button.
3. The country name will show. You can see all available countries when you scroll by pressing “◀” or “▶”
  - North America default (USA/Canada)

**Note:** You cannot change the default country values.

4. Press the ENTER button. This clears the memory. Then it changes it to the country code that you set.

**Note:** Do this procedure after you replace the main board. If you do not do this procedure, the system will not operate correctly.

## 5.2.5 MAINTENANCE

### ***CLEAN DRUM***

Use this feature to remove toner particles that stay in the OPC drum unit.

Use this feature when print quality becomes unsatisfactory or when marks or specks show on the printout. Use this feature one time or more until the printout is clean.

The machine automatically pulls in a sheet of paper and prints out. Toner particles that stay on the OPC drum surface are fused to the paper.

### ***NOTIFY TONER LOW***

If this feature is enabled, when the toner becomes low, a message will be sent to a specified contact point, for example, the service company. To enable this feature, select ON. Then, when the machine asks, input the name and the number of the contact point, the customer's fax number, the model name, and the serial number.

**SWITCH TEST**

Use this to test all keys on the operation panel. The LCD window shows the result when you push a key.

**MODEM TEST**

Use this to hear different transmission signals to the telephone line from the modem and to check the modem. If no transmission signal sound is heard, the modem part of the main board does not operate correctly.

**SRAM TEST**

Use this to test the machine's SRAM. The LCD shows the result.  
The LCD shows << O K >> if the memory operates correctly.

**DRAM TEST**

Use this to test the machine's DRAM. The LCD shows the result.  
The LCD shows << O K >> if the memory operates correctly.

**ROM TEST**

Use this to test the machine's ROM. The LCD shows the result and the software version.

Example:

- FLASH VER: 6.04
- ENGINE VER:7.00

**PATTERN TEST**

Use this to make sure that the printer mechanism operates correctly.

These patterns are printed:

- Pattern-1 ~ Pattern-7
- QA Pattern-1 ~ QA Pattern-4

**CLEAR COUNT**

This clears the counters stored in system memory. These counters are shown in the System Data List (printed in Tech mode). Type password "1934" and press Enter to go into the menu.

You can 'clear' and 'edit' the 'Total Page Counts'. You cannot edit the other counters. You can only clear the other counters.

**Notes:** You cannot erase the 'Current Drum Page Counts' with this service tool. This is cleared using the "NEW DRUM" function (menu 12. Maintenance).

**ANSWER ON CNG**

This function sets the number of CNG tones that the machine must detect before it goes into receive mode from the AUTO mode or ANS/FAX mode.

**ADJUST SHADING**

This function tests the CCD (Charge Coupled Device). Do this when unsatisfactory scanning or copying is reported.

**Procedure**

1. Select [ADJUST SHADING] in tech mode.
2. Press the Enter key. An image will be scanned.
3. After the scan, a CCD Shading Profile (like the one shown to the right) will be output.
4. If the printed image is not the same as the image, the CCD does not operate correctly.

Make sure that the cover is closed when you test the CCD.

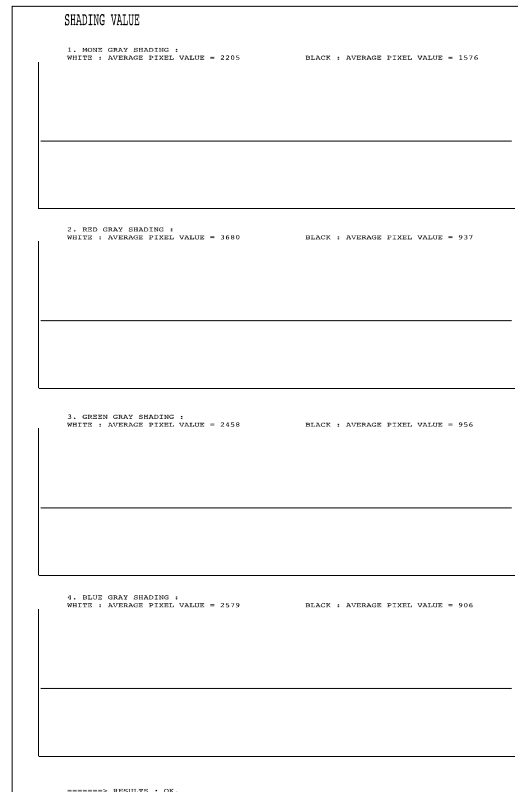

B174S900.WMF

**FLASH UPGRADE**

This function is used to update the system firmware. There are 2 procedures: Local and Remote.

More information can be found in the firmware upgrade section (☛ 5.4).

**PROGRAM DIAL**

Use this to set parameters for a specific dialed location (which must be in the one touch or speed dial phone books). These parameters override the default settings to let the machine make calls to destinations with known line problems.

**REMOTE TEST**

Use this to make available of RDC (Remote Diagnostic Control) access.

## 5.2.6 REPORTS/HELP

### ***PROTOCOL DUMP LIST***

Check this list for send and receive errors. The Protocol Dump List automatically prints if a communication error occurs when the machine is in tech mode.

### ***SYSTEM DATA***

This gives a list of the system data set by the user and those that were set in tech mode.

## 5.3 IDENTIFY SALE DATE

This function confirms the date that the consumer first used the product. The date stored is the date of the first scan or first print, whichever the user did first.

This information is retained even after a memory delete (Clear All Memory,  5.2.4).

### **Method**

1. Press MENU, #, 1, 9, 3, # in sequence. The firmware version is shown on the LCD.
2. Press 1 (in the number keypad): The LCD display shows "Firmware Updated date"
3. Press 2 (in the number keypad): The LCD display shows "Product first use date"



## 5.4 FIRMWARE DOWNLOAD

You can use the remote control panel to upgrade the machine firmware. Connect the machine to a PC through parallel or USB cable before you do the firmware upgrade procedure.

It is very rare to lose data and settings after the program has downloaded. However you should print out the system data list in tech mode before you start the download procedure. This will let you re-program settings that may get lost.

### 5.4.1 LOCAL MACHINE UPDATE

#### ***RCP (Remote Control Panel) mode***

This procedure is used when the machine is connected with a parallel port or USB port to a PC. The machine uses the RCP (Remote Control Panel) software to upgrade the firmware.

1. Connect the PC and the printer with a parallel cable or a USB cable.
2. Start the RCP and select the Firmware Update tab. The current firmware version and emulation version are shown.
3. Keep the firmware file on the PC, in a path near the root of C:, for example C:\TEMP. Use the "Browse" button to get the firmware file to update the machine.
4. Click the update button. The firmware file automatically goes to the printer. The printer is initialized when the update is finished. Make sure that these show on the LCD display when you download the new firmware:
  - 1) DATA RECEIVING (USB) / COPY/B FILE LPT1 (PARALLEL)
  - 2) PC TO DRAM IS OK
  - 3) FLASH IS ERASING
  - 4) FLASH PROGRAMMING
  - 5) CHECKSUMMING
  - 6) DOWNLOAD OK
  - 7) Warming up Please wait...
5. Click the refresh icon. Then make sure that the version number shown agrees with the new firmware.

**Note:** Country code

The country code will not change after you download the new firmware.

#### ***To get the system data list***

Use this procedure to make sure that the firmware was correctly upgraded.

1. Go into TECH mode. Then get the system data list.
2. Make sure that the correct firmware version is shown on the system data list.
  - Example: Firmware Version: 6.04  
Engine Version: 7.00  
Emulation Version: PCL6 3.26 01-05-2004

## 5.4.2 RECOVERY PROCEDURE

The machine will not operate if the update procedure did not work correctly. At this time, do these steps:

1. Turn the power off and then on.
2. Do the steps in the download procedure from step 4 again.

The machine will start the upgrade procedure again.

## 5.4.3 REMOTE MACHINE UPDATE

This function uses one fax machine installed with the most recent firmware. It upgrades one or more other remote machines of the same type with the telephone network.

### *How to update firmware by remote fax*

1. Use a fax machine with the most recent firmware, to prepare it to send the upgrade.
  - Select "Remote" in Flash Upgrade of the Data Setup menu in Tech mode.  
Tech Mode → Data Setup → Flash Upgrade (☛ 5.2.3)
2. Put in the telephone number of the fax machine to upgrade. (You can upgrade several fax machines at the same time). At this time, put in the telephone number for each machine.
3. Then press the enter button. This will send the firmware file to each of the set fax machines. (It will be 10 or 15 minutes to send the file to each machine.)

**CAUTION:** 1) The sending and receiving fax machines must be the same model.  
2) The sending fax must be set up in ECM mode. The receiving machine memory must be set to 100%. If not, the upgrade will fail.

## 5.5 ENGINE TEST MODE

The engine test mode gives functions to test the engine condition. It tests the condition of each device and shows the result of the test on the LCD. The tests are in 6 groups (0~5). The functions of the tests are shown below.

### 5.5.1 TO ENTER THE ENGINE TEST MODE

Press MENU, #, 1, 9, 3, 1 in sequence. When the LCD briefly shows 'Engine Test Mode', the machine is in the service (tech) mode.

**NOTE:** It may cause damage to the machine if a test is done for a long time.

### 5.5.2 DIAGNOSTIC

- Ten key pad '0 - 7' to enter each test
- "<" or ">" to select the setting; Example) "1: On" or "2: Off"
- "^" to move to the next test
- "Mode/Enter" to execute the selected test
- "Menu" to return to the main menu
- "Clear/Stop" to exit the engine test

No.	Engine Test	Remark
0	Motor TEST	1: On, 2: Off
	PTL TEST	1: On, 2: Off
	Fan TEST	1: On, 2: Off
	Fuser TEST	1: On, 2: Off If its temperature is lower than the Standby (160 C), the fuser is on, but if it is higher than the Standby, the fuser is off.
1	LSU Motor TET	1: On, 2: Off
	LSU Hsync TEST	1: On, 2: Off
	LD TEST	1: On, 2: Off
	LSU Operation	1: On, 2: Off
	LSU ERROR INFO	1: On, 2: Off
	LSU VALUE CAL	1: On, 2: Off
2	Feed Sen TEST	Check: Check FEED Sensor Display
		Next: Next Sensor Check
	Exit Sen TEST	Check: Check EXIT Sensor Display
		Next: Next Sensor Check
	Cover Sen TEST	Check: Check COVER Sensor Display
		Next: Next Sensor Check
	1'st Empty TEST	Check: Check 1'st PAPER Empty Sensor Display
		Next: Next Sensor Check
	MP Empty TEST	Check: Check MP PAPER Empty Sensor Display
		Next: Next Sensor Check
	BIN-F Sen TEST	Check: Check BIN FULL Sensor Display
		Next: Next Sensor Check

No.	Engine Test	Remark
3	1'st Sol TEST	1: On, 2: Off
	MP Sol TEST	1: On, 2: Off
	Duplex Sol TEST	1: On, 2: Off
4	MHV TEST	1: On, 2: Off (-1450 V)
	DevBias TEST	1: On, 2: Off (-450 V)
	THV EN/NEG TEST	1: On, 2: Off
	THV On (2000V)	1: On, 2: Off (1300 V)
	THV Trig. TEST	1: On, 2: Off
5	CRU ERR CHECK	1: Check: Check fuse status 2: Next
	NEW OPC CHECK	1: Check: Check if the OPC is new or old 2: Next
6	ALL FUNCTION TEST	For all test (No.0~4), push up key
7	FUSER DEBUG	1: On, 2: Next
	DEBUG VAL CLR	1: Yes, 2: Next
	ERROR INFORM	1: On, 2: Next
	TONER DEBUG	1: On, 2: Next

### 5.5.3 STATUS PRINT

When the function is enabled, a group of parameters are printed at the bottom of each page. This shows the print engine condition. This is not necessary for service use.

This function stays on when you go out of Engine Mode. Make sure to set it off before you go out of Engine Mode.

## 6. DETAILED DESCRIPTION

### 6.1 MAIN PBA (ALSO KNOWN AS MAIN BOARD)

#### 6.1.1 SUMMARY

The main circuit contains the CPU, MFP controller (built-in 32-bit RISC processor core: ARM946ES). It includes I/O device drivers, system memory, scanner, printer, motor driver, PC I/F, and fax transceiver, and it controls all the system. The structure of the main circuit is shown below.

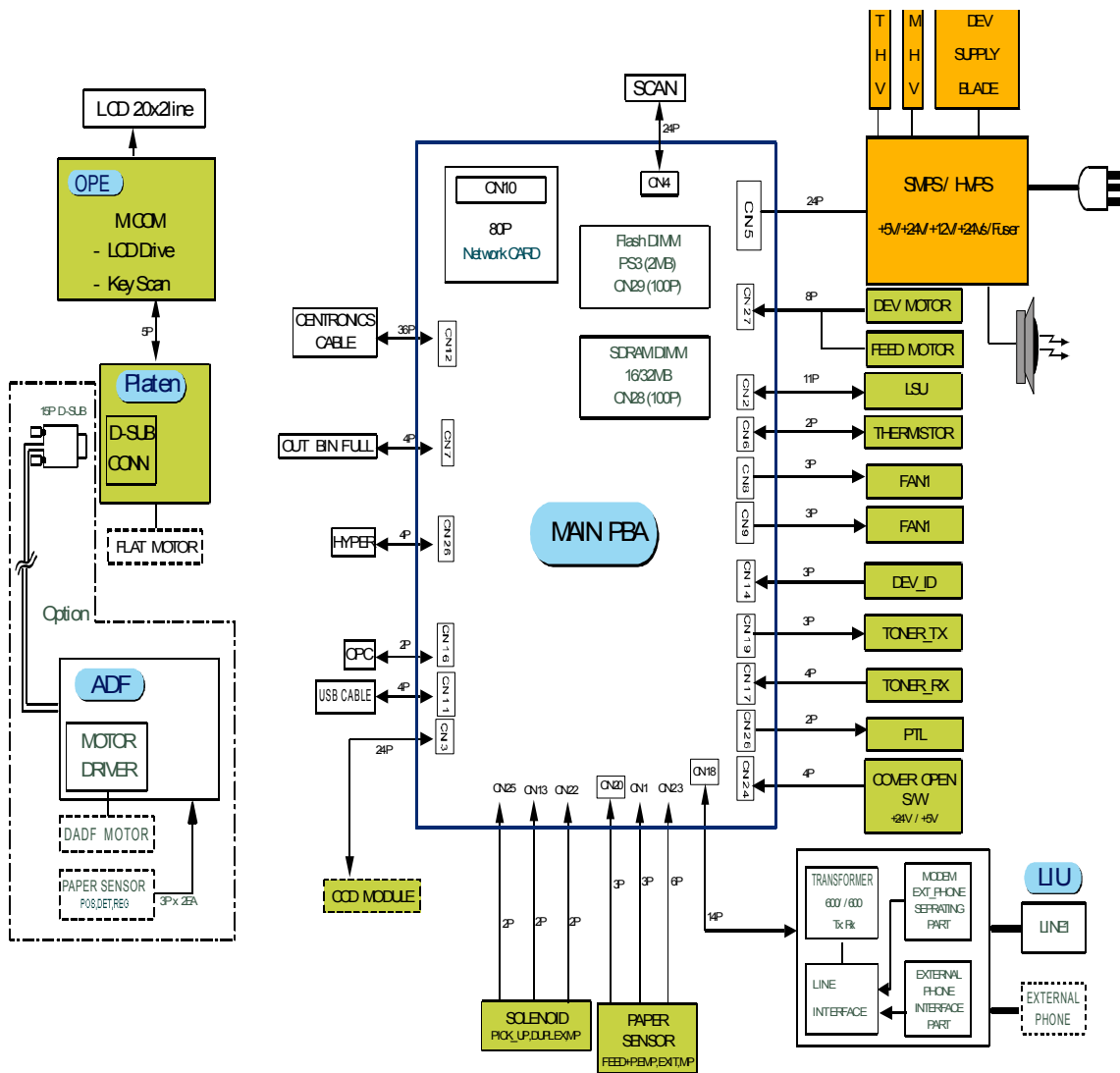

Detailed Descriptions

B174D901.WMF

## 6.2 CIRCUIT OPERATION

### 6.2.1 FAX TRANSCEIVER

#### **General**

This circuit controls the transmission signals from the modem and signals between LIU and modem.

#### **Modem (u44)**

FM336 is a one-chip fax modem. It controls DTMF detection and DTMF signal generation, and the modem functions. TX A1, 2 is the transmission output port and RX IN is the received data input port. The /POR signal, controlled by the MFP controller (U3:ARM946ES), can initialize the modem (/M\_RST), and at this time the system does not turn off.

D0-D7 is an 8-bit data bus. RS0-RS4 signals select the register in the modem chips. The /RS signal controls reading, and the /WR signal controls writing. /IRQ is a signal for modem interrupt.

FM336 can give transmission speeds of 33.6k maximum.

The modem is connected to the line through a transformer directly.

## 6.3 SCANNER

### 6.3.1 SUMMARY

This flat-bed type device to scan originals has a 600dpi CCD as an image sensor. There is one optical sensor to detect CCD home position and scan-end position. The home position is detected by an optical sensor, which is attached to the CCD Module. The scan-end position is calculated by the number of motor steps.

#### **CCD**

This machine uses a color CCD.

- Minimum Scan Line Time for One Color: 2.5 ms
- Light Source Power: +18V
- Maximum Pixel Frequency: 10MHz
- Effective Sensor Elements: 5340 X 3
- Clamp Level: 0.7~ 0.8V
- Bright Output: Min 0.8V

## 6.3.2 KEY FEATURES

### **Overview**

1. 0.5 $\mu$ m C-MOS process (TLM), 208-PIN QFP, STD85 library
2. Frequency: Max PLL 80 MHz
3. On-Chip oscillator
4. Method: Raster scanning method
5. Image Source: 300/400/600dpi CIS & CCD
6. Scanning Mode
  - Color gray image: each 8 bits / RGB
  - Mono gray image: 8 bits / pixel
  - Binary image: 1 bit / pixel (for text/photo/mixed mode)
7. Maximum scanning width: A3, 600dpi (8K effective pixels)
8. Ideal MSLT (A4, 600/300dpi)
  - Color gray image: 3x5Kx80 nsec = 1.2 msec (7/28 CPM)
  - Mono gray image: 1x5Kx80 nsec = 0.4 msec (21/84 CPM)
  - Binary image: 1x5Kx80 nsec = 0.4 msec (21/84 CPM)
9. A/D conversion depth: 12 bits

### **Pixel processing structure**

- Minimum pixel processing time: 4 system clocks
- High speed pipelined processing method  
(Shading correction, Gamma correction, Enlargement/Reduction, and Binary conversion)

### **Shading Correction**

1. White shading correction support for R/G/B
2. White shading data memory: 3x8Kx12 bits = 288K bits → 384K bits (external)
3. Black shading data memory: 3x8Kx12 bits = 288K bits → 384K bits (external)

### **Gamma Correction**

1. Independent Gamma table for each RGB component
2. Gamma table data memory: 3x1Kx8 bits = 24K bits (internal)

**Binary conversion (mono)**

1. 256 grey scales for photo documents: 3x5 EDF (Error Diffusion) method proposed by Stucki.
2. LAT (Local Adaptive Thresholding) for Text documents:
  - Use of 5x5 Local Window (Tip Algorithm)
  - ABC (Automatic Background Control): T<sub>min</sub> Automatic change
3. Mixed mode processing for text/photo mixed documents
4. EDF data memory: 2x4Kx16 bits = 128K bits (internal)
5. LAT data memory: 4x4Kx16 bits = 256K bits (external)

**Scaling of input image**

1. Scaling factor
  - Horizontal direction: 25 ~ 800% by 1% unit
  - Vertical direction: 25 ~ 100% by 1% unit
2. Scaling data memory: 2x8Kx8 bits = 128K bits (internal)

**Intelligent scan motor controller**

1. Automatic acceleration/deceleration/uniform velocity
2. Data memory: 256x16 bits = 4K bits (internal)

**Auto-Run**

Automatic CLK\_LINE (line processing start control) and øTG (line scan start control) signal generation.

1. Available resynchronization of øTG signal
2. Programmable øTG's period & CLK\_LINE's occurrence number

**Processed data output format in DTM (Data Transfer Module)**

1. DMA mode: Burst/On-demand mode
2. CDIP I/F: LINE\_SYNC, PIXEL\_SYNC, PIXEL\_DATA[7:0]

**Others**

36 General Purpose Input/Output ports: 8 (GPO), 28 (GPIO)  
Black/White inversion, and Image Mirroring support



## 6.4 SMPS & HVPS (ALSO KNOWN AS PSU AND POWER PACK)

The SMPS (Switching Mode Power Supply) and HVPS (High Voltage Power Supply) are on the same board.

### 6.4.1 SUMMARY OF SMPS

The SMPS unit is a PWM (Pulse Width Modulation) type power supply unit that supplies DC+5V to the controller and operation panel, and DC+5V, DC+24V and DC+12V to the engine. It also supplies AC power to the fusing lamp.

### 6.4.2 SUMMARY OF HVPS

It is the high voltage power supply that has DC+24V/DC+5V (used for the image forming device in digital picture developing method) as the rated inputs. It supplies electrifying voltage (MHV), supply voltage (SUPPLY), developing voltage (DEV), blade voltage (BLADE) and transferring voltage (THV).

## 6.5 ENGINE CONTROLLER

### 6.5.1 FUSING CONTROL/THERMISTOR CIRCUIT

This circuit controls the fusing lamp temperature. It contains a thermistor, the LM393 (voltage comparator), and a transistor for switching.

The resistance of the thermistor decreases in proportion when the surface temperature of the hot roller increases. The voltage is read by pin 60 (AVIN2) of the CPU. The CPU refers to the parallel combined resistance with the resistor (R43) connected parallel to it and the voltage distribution from R29. The voltage that is read changes the 'fuser' signal to high (or low) referring to the set temperature. Then, when the 'fuseron' signal turns low (high) by Q3 switching, the S21ME4 inside SMPS (PC3) turns on (off) and this turns the two-way thyristor (SY1) on (off) to allow (stop) the AC voltage to the fusing lamp.

LM393 is a H/W that protects the system when the fusing lamp control software does not operate correctly.

When the thermistor temperature goes up to 210°C, the level of pin 1 (LM393) will turn low to turn the 'fuseron' signal to high (this forcefully shuts off Q3). In other words, LM393 shuts off the fusing lamp forcefully.

## 6.5.2 PAPER DETECTION CIRCUIT

### 1) *Cover Open Detection*

The cover open sensor is on the right rear side of the printer. If the right cover is open, it stops the +5V (LSU laser unit) and +24V (main motor, polygon motor, fixer LSU and HVPS) that are supplied to each unit. When the CPU detects that the cover is open, the red LED on the operation panel will turn on.

### 2) *Paper Empty Detection*

The paper empty sensor (photo interrupter), at the bottom of the cassette detects paper with the actuator connected to it and tells the CPU if there is paper. When there is no paper in the cassette, the red LED on the operation panel will turn on to tell the user to fill the cassette with paper.

### 3) *Paper Feeding*

When the paper is fed into the unit and goes past the actuator of the feed sensor unit, the transistor inside the photo interrupter will turn on, the 'nFEED' signal will turn low and tell the CPU that paper is fed into the machine. The CPU detects this signal and writes video data to the OPC after a set time (related to the paper size setting). If the paper does not get to the feed sensor within a set time, the CPU detects this as "Paper Jam0" (the red LED on the operation panel will turn on).

### 4) *Paper Exit Detection*

The system detects paper going out of the unit with the exit sensor and the actuator attached to the frame. If the CPU input does not turn back high a set time after the paper hits the exit sensor, the CPU detects this as "Paper Jam2" (the red LED on the operation panel will turn on).

## 6.6 LIU (ALSO KNOWN AS NCU)

### 6.6.1 SUMMARY

The LIU connects the main board's modem to the telephone line. It also contains circuits for impedance matching (AC, DC), ring detection and line connection (DIALER).

### 6.6.2 DIALER

#### **TONE DIAL**

DTMF Dialing is controlled by the modem and should be selected by appropriate level and on-off time output based on each countries' own national specification.

- Freq. Tolerance:  $\pm 1.5\%$   
 High Group: 1209, 1336, 1477, 1633Hz  
 Low Group: 697, 770, 852, 941 Hz

	<b>U.S. Usage</b>	<b>CTR21</b>
<b>High Freq Level</b>	-9.0+2.0/-2.5	-7.0 +1.0/-2.0
<b>Low Freq Level</b>	-9.0+1.0/-2.0	-11.0+2.5/-2.0

#### **PULSE DIAL**

Controlled from MAIN through the / DP-Terminal.

For U.S. usage, set a time to the DF signal of 40:60 M/B. The DP signal is made of U6 (pcb817). The DC current that flows thru the Q2 Base is regulated by an On/Off switch and turns the DP dial signal on/off with a coupler.

CTR 21 does not have telephone capability but has the number 3 and 4 Line Connection. It has no DP condition but there is a possibility to get approval only on a DTMF Dial based terminal.

Detailed Descriptions

# SPECIFICATION

Specifications are correct at the time of printing. Product specifications are subject to change without notice.

See below for product specifications.

## 1. GENERAL SPECIFICATIONS

Item	Description	
Type of Unit:	Desktop	
Operation System:	Win95/98/Win-Me/NT4.0/2000/XP	
Duplex Printing:	Yes (Standard)	
Interface:	IEEE1284 (ECP)	
	USB1.1 (without HUB mode)	
CPU:	120 MHz (ARM946ES)	
Emulation:	PCL6	
Warming up Time:	45 Sec (Stand-By), 22°C	
Absolute Storage Condition:	Temperature:	-20°C ~ 40°C
	Humidity:	10% RH ~ 95% RH
Operating Condition:	Temperature:	10°C ~ 32°C
	Humidity:	20% RH ~ 80% RH
Recommended Operating Condition:	Temperature:	16°C ~ 30°C
	Humidity:	30% RH ~ 70% RH
Dimension (W X D X H) :	560 x 433 x 459mm (22.0" x 17.0" x 18.1")	
Weight:	About 22.5 Kg (with consumables)	
	About 21.3 Kg (without consumables)	
Acoustic Noise:	Less than 56/50 dB (Copy/Printing mode)	
Power Rating:	AC 100 VAC ~ 127 VAC, 50/60 Hz ± 3 Hz	
Power Consumption:	Avg. 350 Wh, (Standby: 90 Wh)	
Power Save Consumption:	Avg. 30 Wh	
Recommended System Requirement:	Pentium IV 1.2 Ghz, 128 MB RAM, 220 MB (Hard Disk)	
Minimum System Requirement:	Pentium II 400 Mhz, 64 MB RAM, 120 MB (Hard Disk)	
LCD:	16 characters x 2 lines	
Memory:	4 Mbyte for flash Memory , 16 Mbyte for SDRAM	

## 2. PRINT SPECIFICATION

Item	Description
Printing Method:	Laser Scanning Unit + Electro Photography
Speed:	Single Side: A4 - 15 PPM, Letter - 16 PPM (5% Character Pattern)
	Duplex : 9 IPM (Images/Min) (A4 Size, 5% Character Pattern)
Source of Light:	LSU (Laser Scanning Unit)
Duplex Printing:	Yes (Default)
Resolution	True 600 X600 DPI , 1200 DPI Class
Feed Method:	Cassette, Bypass Tray (MP Tray),
	ADF (Automatic Document Feeder)
Feed Direction:	FISO (Front-In Side-Out)
Paper Capacity (Input) :	Cassette: 550 Sheets (based on 75g/m <sup>2</sup> , 20 lb)
	Bypass Tray: 100 Sheets (based on 75g/m <sup>2</sup> , 20 lb)
Paper Capacity (Output) :	Face Down: 250 Sheets
Effective Print Width:	203 ± 1mm (8.0")

## 3. SCAN SPECIFICATION

Item	Description
Type:	Flatbed (with ADF)
Speed:	Mono : 1.25 msec/line, Color : 2.5 msec/line
Device:	Color CCD (Charge Coupled Device) Module
Interface:	IEEE1284 (ECP Support)
	USB 1.1 (without HUB Mode)
Compatibility:	TWAIN Standard, (WIA)
Resolution	Optical   600 X 600 dpi (Mono and color)
	Enhanced   Max. 4800 dpi
Halftone:	256 Levels
Effective Scan width:	8.2 inches (208 mm)

### 4. COPY SPECIFICATION

Item	Description	
Mode:	B/W	
Quality:	Text/Photo/Mixed	
Mono Copy Speed <sup>(Note)</sup> :	Platen	SDMP: 15 cpm
	ADF	SDMP: 15 cpm
		MDSP: Text/mixed : Approx. 8 cpm
		Photo: Approx. 4 cpm
Optical Resolution	600 x 600 dpi	
Multi Copy	999 pages	
Maximum Original Size	Legal	
Maximum Paper Size	Legal	
Paper Type Selection	Plain, Legal, Cardstock, Transparency	
Zoom Range	Platen: 25 ~ 400% (1% Step)	
	ADF: 25~100 % (1% Step)	

**NOTE:** Speed claims based on the test chart: A4 size.  
 SDMP: Single Document Multiple Printout  
 MDSP: Multiple Document Single Printout

### 5. TELEPHONE SPECIFICATION

Item	Description
Speed Dial:	80 locations
Tone/Pulse:	Tone only user mode, Tone/Pulse selectable in Tech mode.

### 6. FAX SPECIFICATION

Item	Description
Compatibility:	ITU-T Group3, ECM
Communication System:	PSTN or behind PABX
	(PSTN: Public Switched Telephone Network. PABX: Private Automatic Branch Exchange)
Compression:	MH/MR/MMR/JPEG (Transmission)
Modem speed:	33.6/28.8/21.6/19.2/14.4/12/9.6/7.2/4.8/2.4 kbps, Automatic fallback
Transmission Speed:	Approximately 3 sec (33.6 kbps)
Effective Scanning Width:	8.2 inches (208 mm)
Halftone:	256 Levels
Paper Capacity (Input):	ADF (Automatic Document Feeder) : 30 sheets (75g/m <sup>2</sup> , 20 lb)
FAX Mode:	Standard /Fine/Super Fine/Halftone
Memory:	4MB

Spec.

## 7. PAPER HANDLING

Item		Description
Capacity (based on 75g/m <sup>2</sup> , 20 lbs):	Main Tray	550 sheets
	Bypass (MP Tray)	100 sheet
Optional Cassette:		No
Output Capacity (based on 75g/m <sup>2</sup> , 20 lbs):		250 sheets
Output Control:		Face down, Internal Tray
Paper Type and Size:	Main tray • Plain paper	A4, Letter (8 ½" x 11"), Legal (8 ½" x 13"), 8 ½" x 14"
	Bypass • Plain paper • Envelope • Transparency • Film • Label • Cardstock	A6, A5, A4, B5 7 ¼" x 10 ½", 8 ½" x 11", 8 ½" x 13", 8 ½" x 14"  Irregular size: 98-216 x 148-356 mm (3.9" - 8 ½" x 5.8" - 14")
	Duplex • Plain paper	A4, Letter (8 ½" x 11"), Legal (8 ½" x 13"), 8 ½" x 14"
Paper Weight:	Main tray	60 ~ 90g/m <sup>2</sup> (16 ~ 24 lb)
	Bypass	60 ~ 161g/m <sup>2</sup> (16 ~ 43 lb)
	Duplex	75 ~ 90g/m <sup>2</sup> (20 ~ 24 lb)
Input Guide:	Bypass tray	Adjustable
	Main tray	Universal
	Document	Adjustable
ADF:	Paper Weight	50 ~ 105g/m <sup>2</sup> (12.5 ~ 28lb)
	Capacity	30 sheets (20 lb)
	Document size width	174mm ~ 216 mm (6.9" ~ 8.5")
	Document size length	128 mm ~ 356 mm (5.0" ~ 14.0")

## 8. CONSUMABLES

Item	Description
Type:	Separate type
	Toner Cartridge
	Drum Cartridge

# APPENDIX

## BLOCK DIAGRAMS

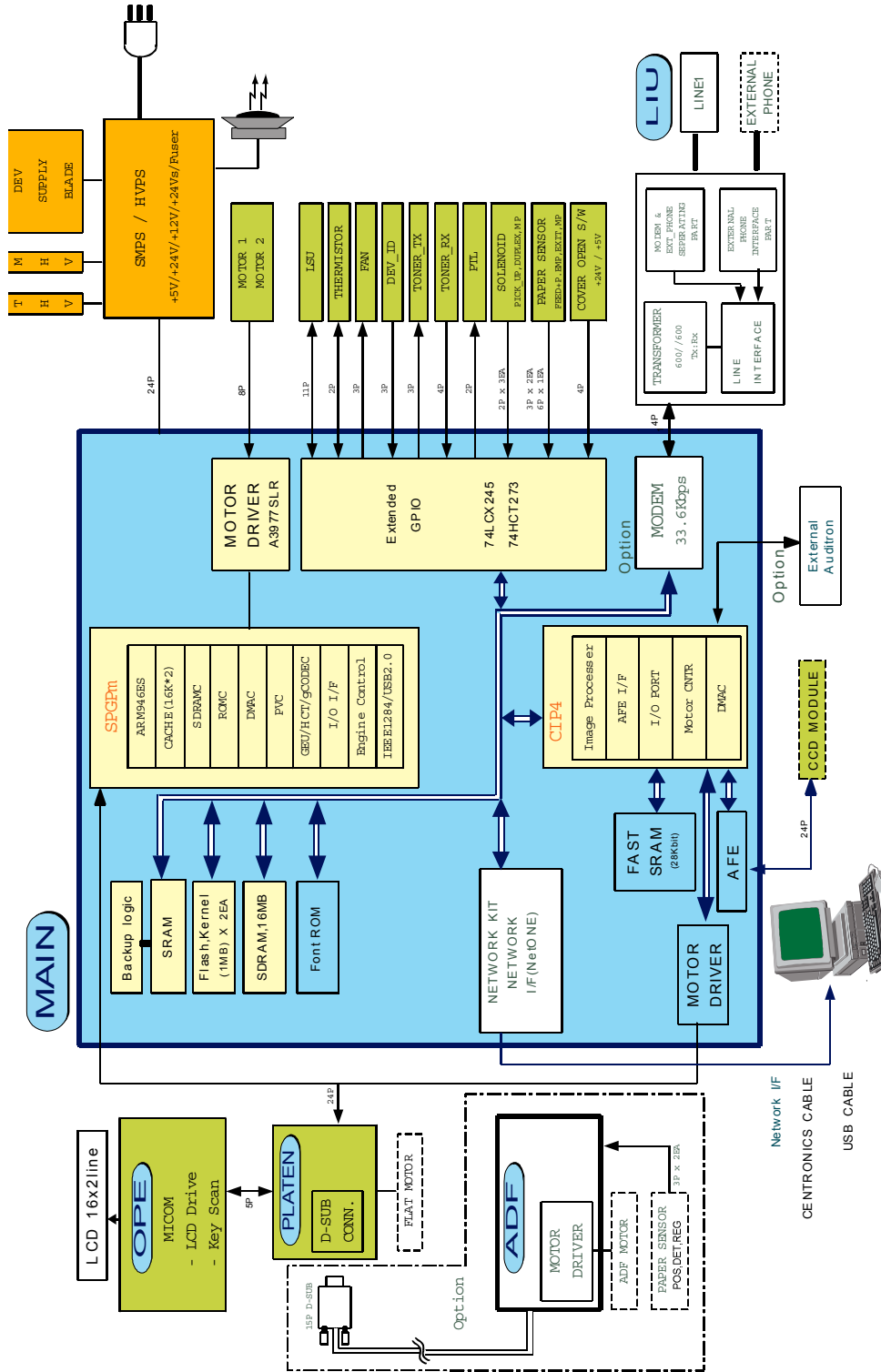

B174X900A.WMF



CONNECTION DIAGRAMS

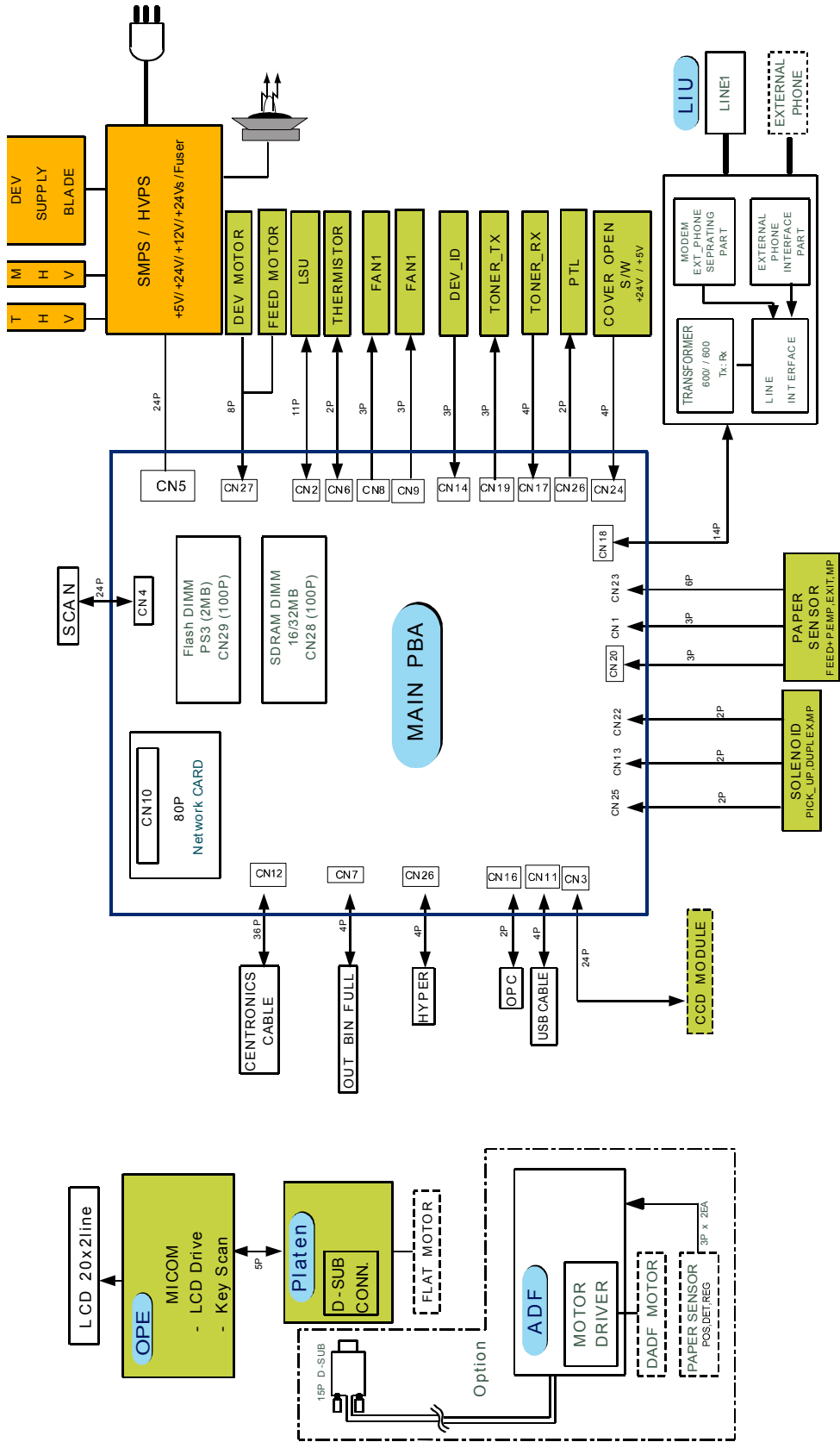

B174X901A.WMF

---

# PARTS CATALOG

## Contents

1. MAIN ASSEMBLY .....	2
2. PLATEN ASSEMBLY.....	4
3. ADF ASSEMBLY .....	7
4. SIDE COVER ASSEMBLY .....	9
5. CASSETTE ASSEMBLY.....	10
6. EXIT ASSEMBLY .....	11
7. FEEDER ROLLER ASSEMBLY.....	12
8. MP ASSEMBLY .....	13
9. BASE FLAME ASSEMBLY .....	14
10. PICK-UP ASSEMBLY .....	15
11. DRIVER ASSEMBLY .....	16
12. MAIN FRAME ASSEMBLY .....	17
13. FUSER ASSEMBLY .....	19
<b>PARTS CATALOG INDEX.....</b>	<b>20</b>

# 1. MAIN ASSEMBLY

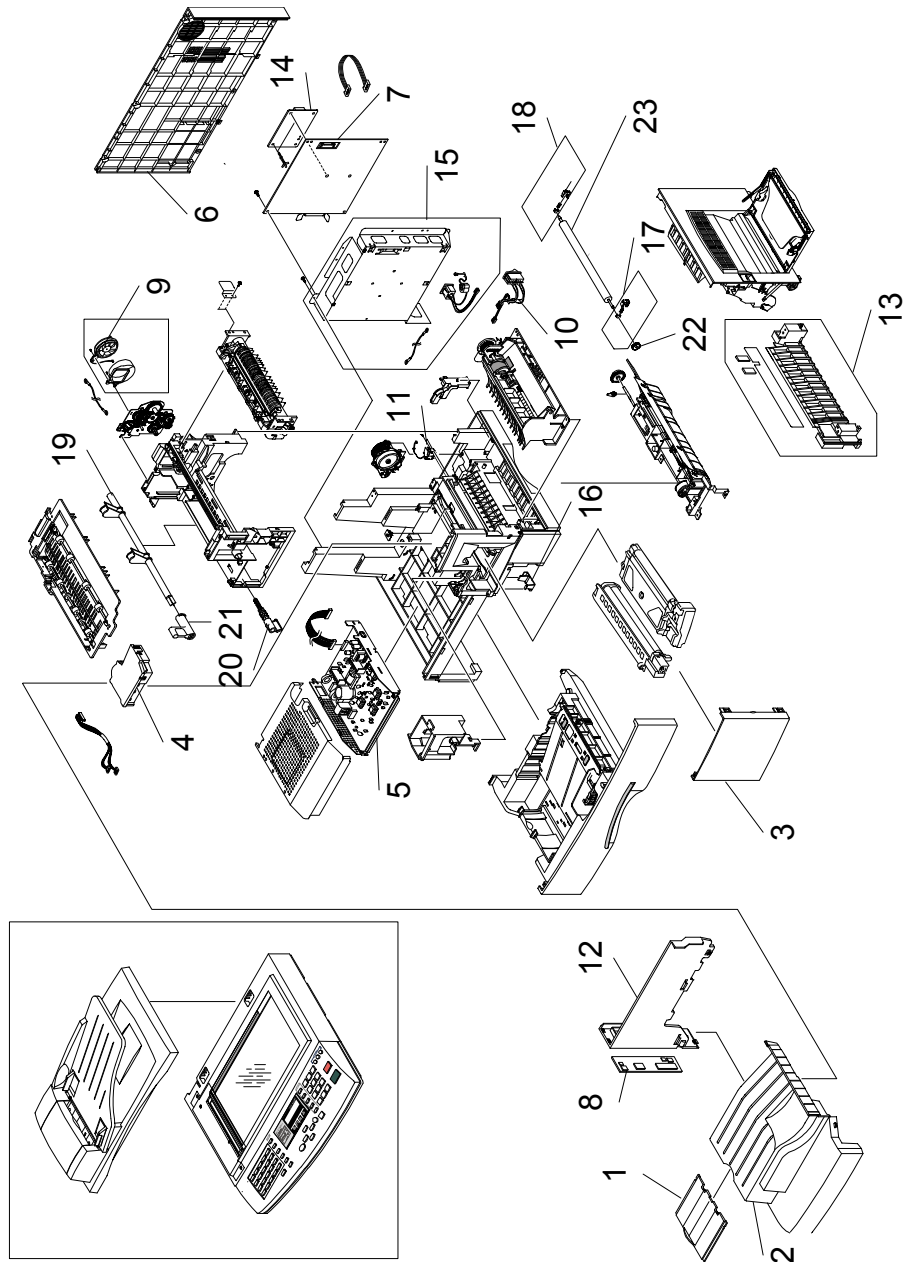

B174C900.WMF

Index No.	Part No.	Description	Q'ty	B174
				17
1	B1749500	COPY TRAY EXTENTION	1	O
2	B1749501	COPY TRAY	1	O
3	B1749502	FRONT COVER	1	O
4	B1749503	LASER UNIT	1	O
5	B1749504	PSU - 110V	1	O
6	B1749505	REAR COVER	1	O
7	B1749506	PCB - MAIN BOARD	1	O
8	B1749507	INTERFACE PANEL	1	O
9	B1749508	COOLING FAN	1	O
10	B1749511	MAIN SWITCH	1	O
11	B1749512	PICK-UP SOLENOID	1	O
12	B1749513	LEFT COVER	1	O
13	B1749514	CASSETTE GUIDE	1	O
14	B1749515	PCB - NCU : NA	1	O
15	B1749517	SHIELD PLATE - MAIN	1	O
16	B1749520	GUIDE - PAPER EXIT	1	O
17	B1749527	HOLDER ASS'Y - TRANSFER ROLLER : R	1	O
18	B1749528	HOLDER ASS'Y - TRANSFER ROLLER : L	1	O
19	B1749534	CAM - PAPER EXIT	1	O
20	B1749535	LOCK LEVER - TONER CARTRIDGE	1	O
21	B1749536	LEVER - PAPER EXIT	1	O
22	B1749529	GEAR - TRANSFER ROLLER	1	O
23	B1749530	TRANSFER ROLLER	1	O

## 2. PLATEN ASSEMBLY

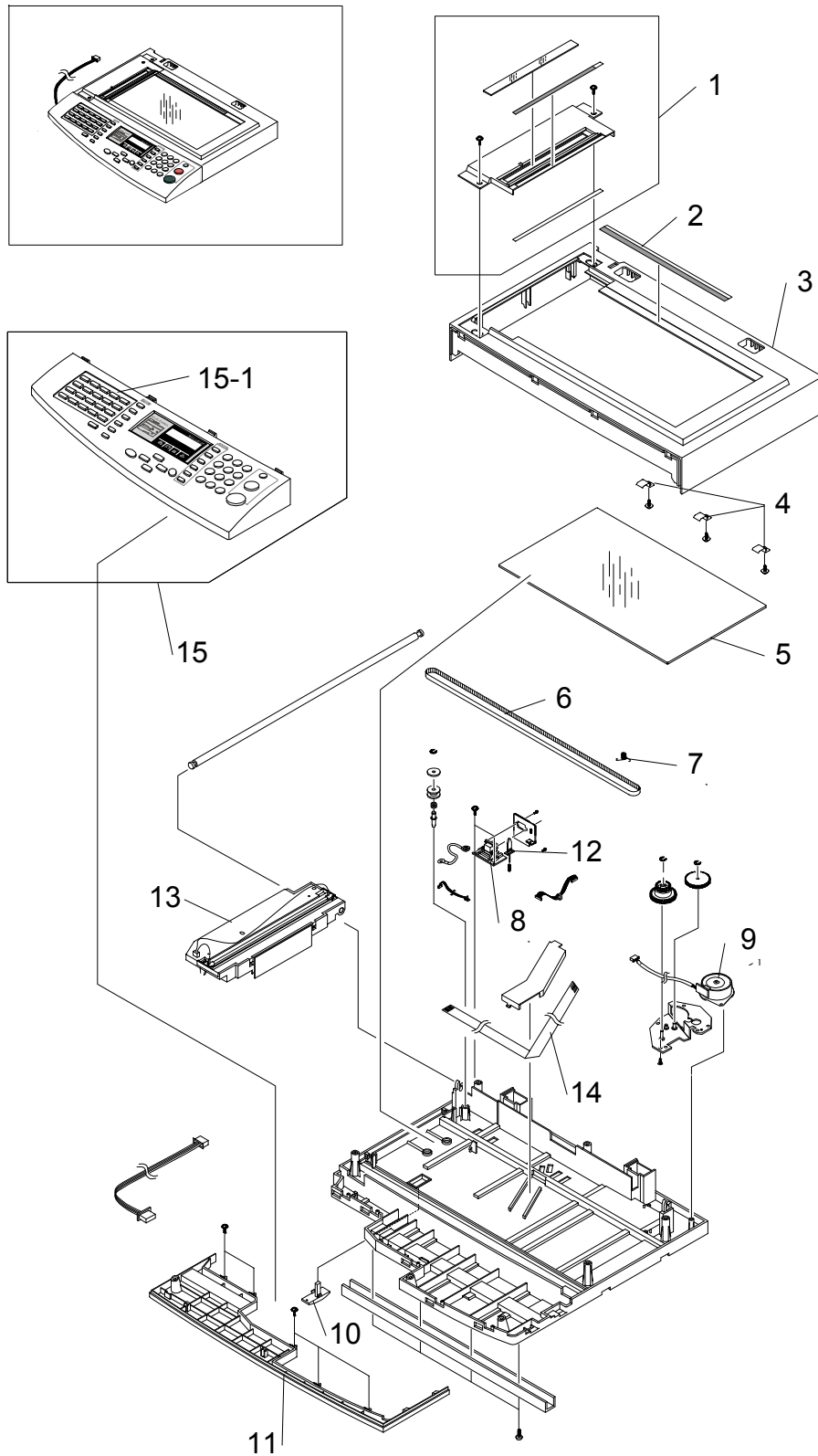

B174C901.WMF

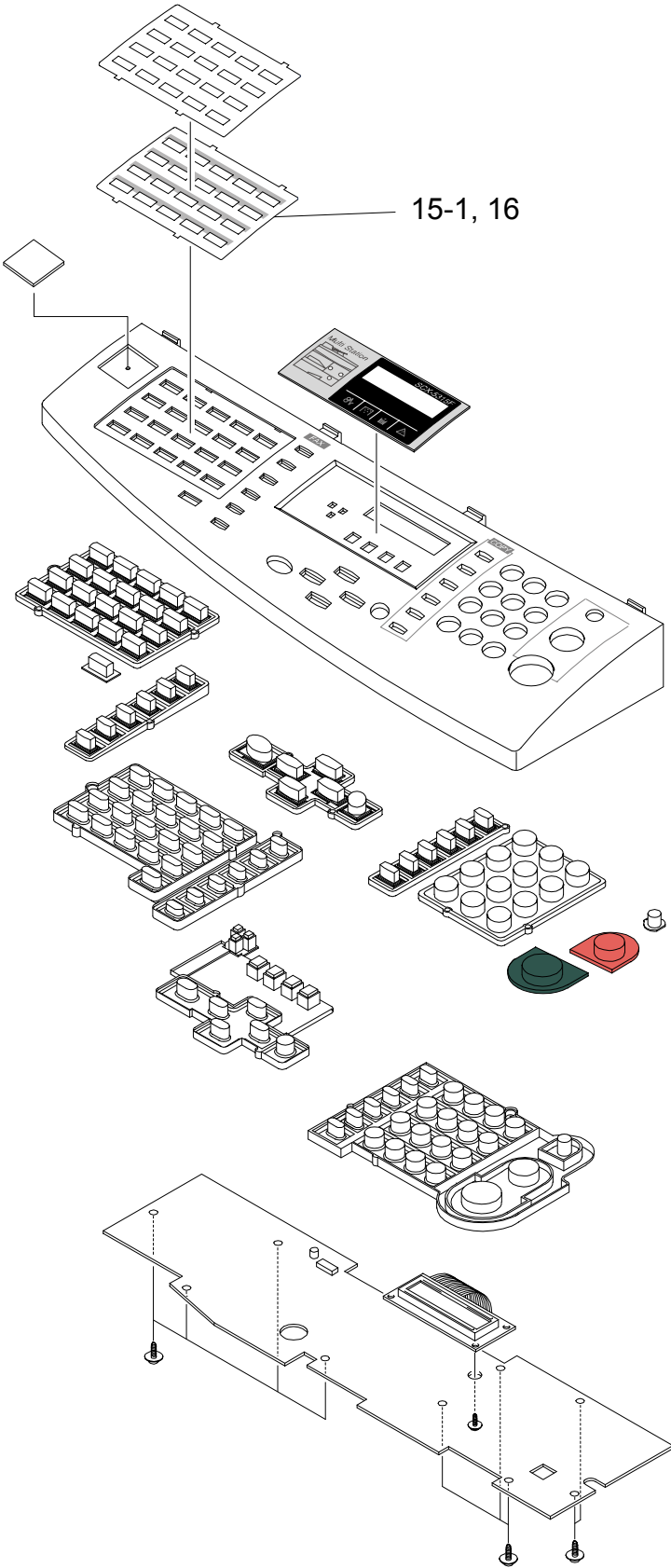

B174C902.WMF

Index No.	Part No.	Description	Q'ty	B174
				17
1	B1749538	PLATEN COVER ASS'Y - ADF	1	O
2	B1749539	SCALE - SUB DIRECTION	1	O
3	B1749540	SCANNER COVER	1	O
4	B1749541	HOLDER - PLATEN GLASS	3	O
5	B1749542	PLATEN GLASS	1	O
6	B1749543	TIMING BELT - SCANNER	1	O
7	B1749544	SPRING - TIMING BELT	1	O
8	B1749547	PCB - SCANNER BOARD	1	O
9	B1739606	SCANNER MOTOR	1	O
10	B1749557	CCD HOLDER	1	O
11	B1749558	SCANNER BASE - OP-PORT	1	O
12	B1739601	SENSOR LEVER	1	O
13	B1749565	CCD UNIT	1	O
14	B1749566	FLAT CABLE - CCD	1	O
15	B1749739	OP-PORT ASS'Y - NA	1	O
15-1	B1749740	ONE TOUCH KEY SHEET - ENGLISH - MB001 DELETED	1	O
15-1	B1749744	ONE TOUCH KEY SHEET - ENGLISH - MB001 ADDED	1	O
16	B1749741	ONE TOUCH KEY SHEET - FRENCH	1	O
16	B1749742	ONE TOUCH KEY SHEET - SPANISH	1	O
16	B1749743	ONE TOUCH KEY SHEET - PORTUGUESE	1	O

### 3. ADF ASSEMBLY

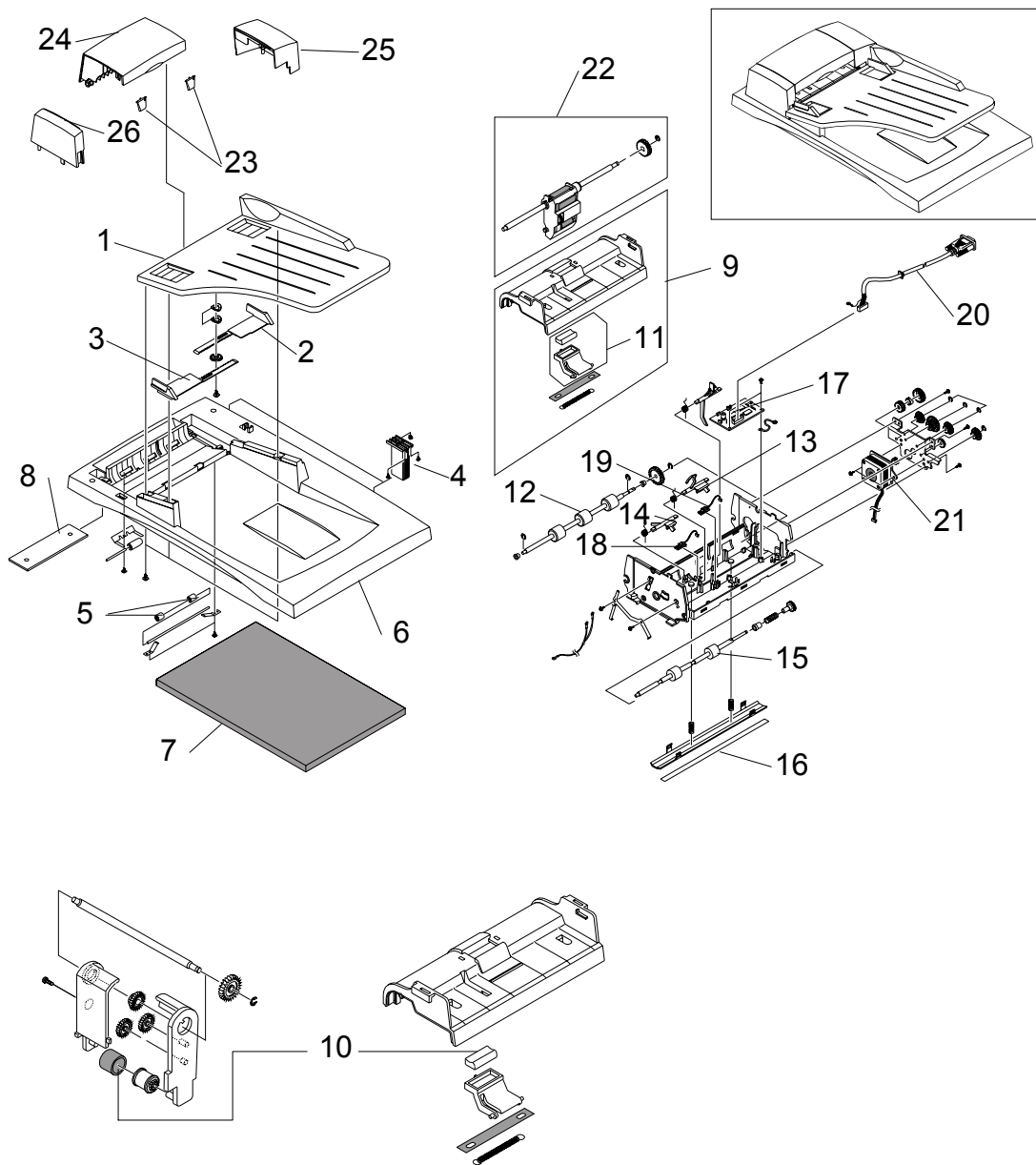

B174C903.WMF



Index No.	Part No.	Description	Q'ty	B174
				17
1	B1749568	DOCUMENT TABLE	1	O
2	B1749570	DOCUMENT GUIDE - LEFT	1	O
3	B1749571	DOCUMENT GUIDE - RIGHT	1	O
4	B1749573	HINGE ASS'Y	2	O
5	B1739583	EXIT ROLLER - PLATEN	2	O
6	B1749577	PLATEN COVER	1	O
7	B1749578	SPONGE SHEET	1	O
8	B1749579	WHITE SHEET - ADF	1	O
9	B1749582	ADF UPPER ASS'Y	1	O
10	B1749738	ADF RUBBER KIT	1	O
11	B1749583	ADF RUBBER PAD ASS'Y	1	O
12	B1749587	DRIVE ROLLER	1	O
13	B1749589	ACTUATOR - DOCUMENT SENSOR	1	O
14	B1749590	ACTUATOR - REGIST SENSOR	1	O
15	B1749591	EXIT ROLLER	1	O
16	B1749597	WHITE SHEET	1	O
17	B1749598	PCB - ADF:SUB	1	O
18	B1749599	REGIST SENSOR	1	O
19	B1749600	DOCUMENT SENSOR	1	O
20	B1749604	ADF MAIN CABLE	1	O
21	B1749605	ADF MOTOR	1	O
22	B1749606	ADF PICK-UP ASS'Y	1	O
23	B1739586	PAPER GUIDE - ADF TOP COVER	2	O
24	B1749608	ADF TOP COVER	1	O
25	B1749609	ADF SIDE COVER - LEFT	1	O
26	B1749610	ADF SIDE COVER - RIGHT	1	O

## 4. SIDE COVER ASSEMBLY

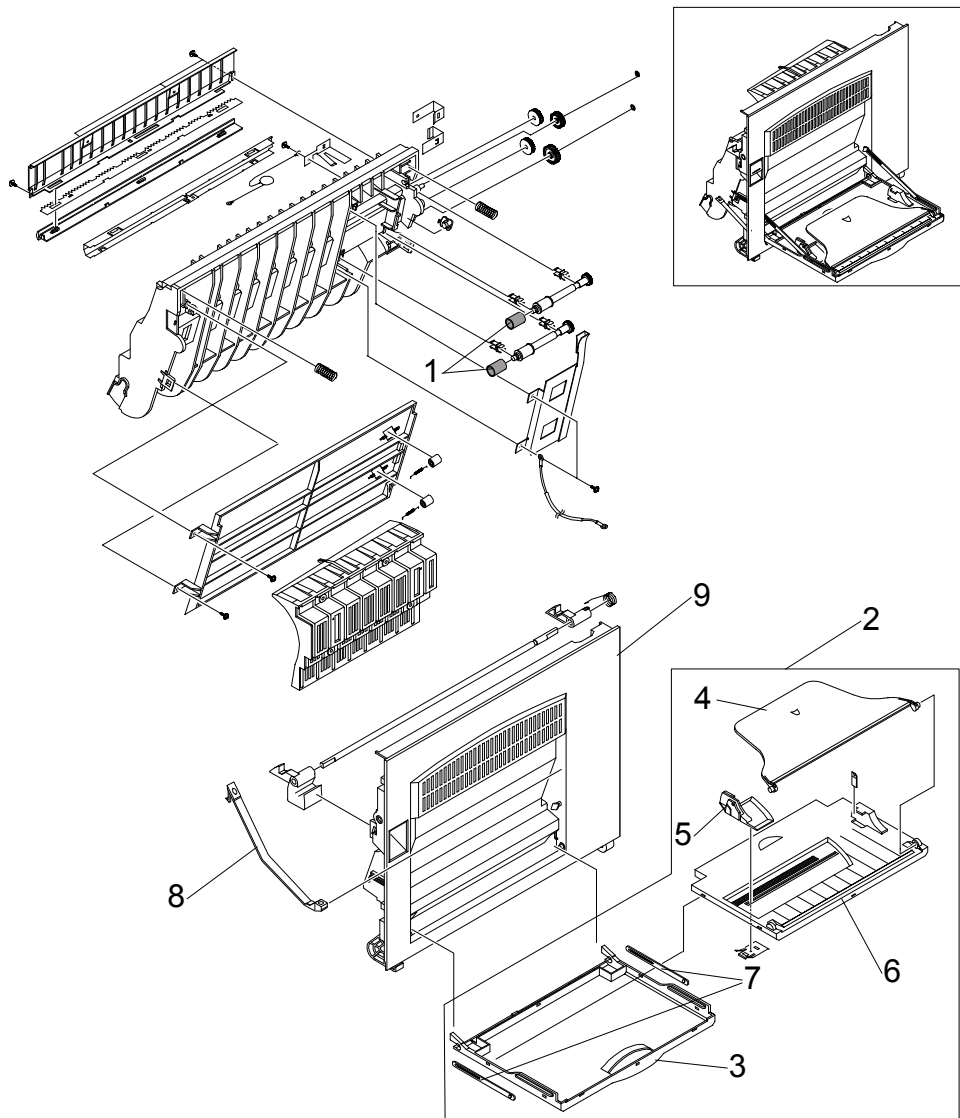

B174C904.WMF

Index No.	Part No.	Description	Q'ty	B174
				17
1	B1749618	RUBBER - EXIT	2	O
2	B1749628	BYPASS TRAY ASS'Y	1	O
3	B1749629	CASE - BYPASS TRAY	1	O
4	B1749630	EXTENSION - BYPASS TRAY	1	O
5	B1749631	PAPER GUIDE - BYPASS TRAY	1	O
6	B1749632	COVER - BYPASS TRAY	1	O
7	B1749634	TRAY LINK - BYPASS	2	O
8	B1749637	TIE STRAP	2	O
9	B1749644	RIGHT COVER	1	O

## 5. CASSETTE ASSEMBLY

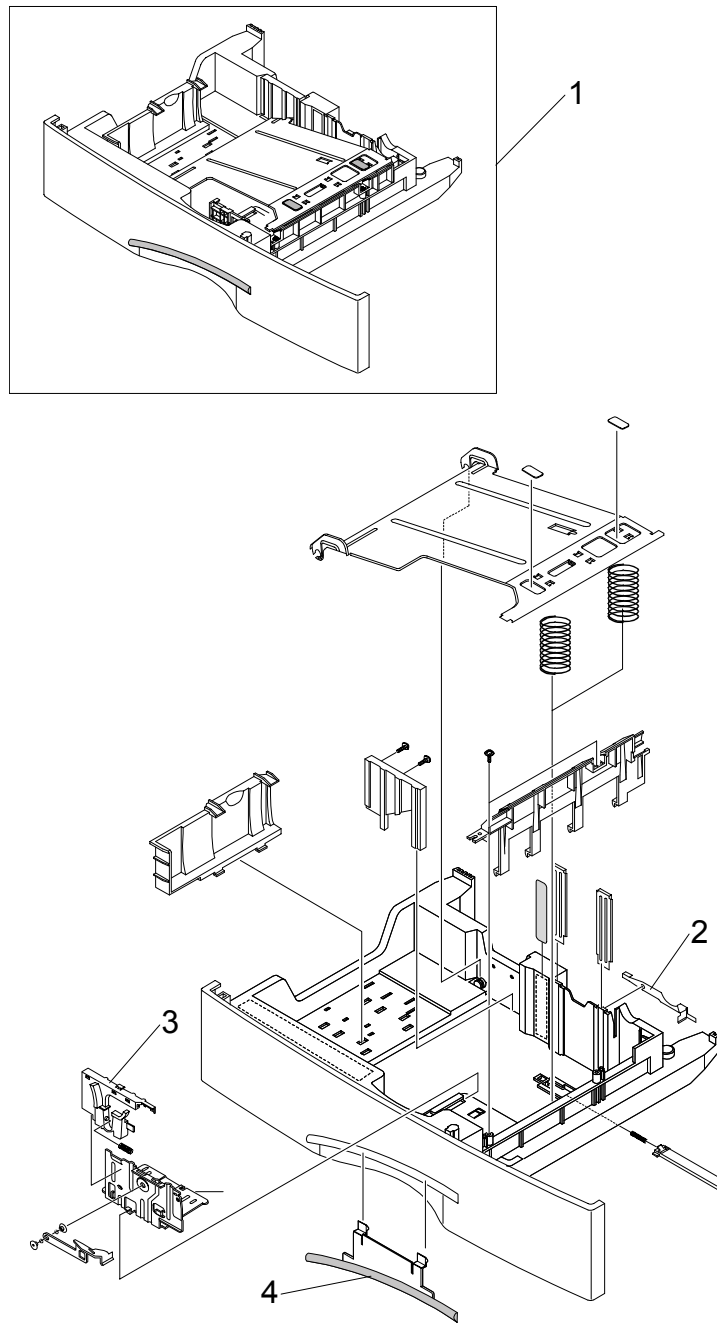

B174C905.WMF

Index No.	Part No.	Description	Q'ty	B174
				17
1	B1749646	CASSETTE ASS'Y	1	O
2	B1749647	PAPER FINGER - RIGHT	1	O
3	B1749655	HANDLE - SIDE FENSE	1	O
4	B1749660	CASSETTE GRIP	1	O

## 6. EXIT ASSEMBLY

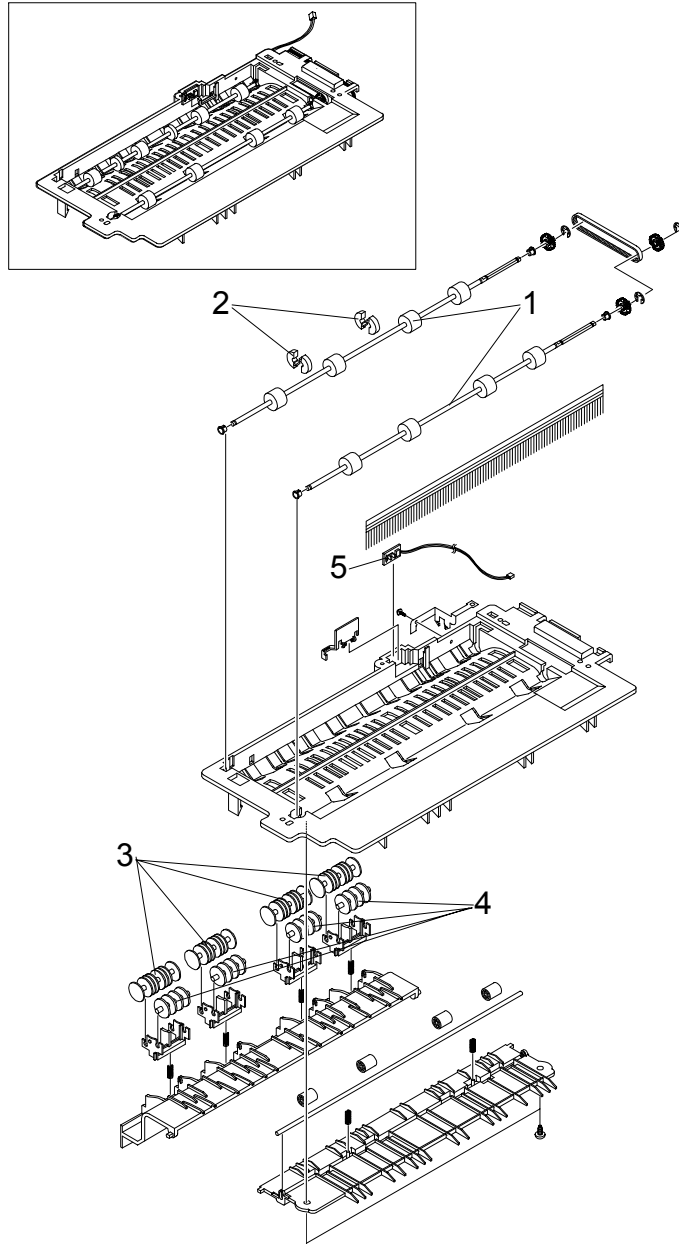

B174C906.WMF

Index No.	Part No.	Description	Q'ty	B174
				17
1	B1749663	EXIT ROLLER	2	O
2	B1749664	DECURL - EXIT ROLLER	4	O
3	B1749670	IDLE - EXIT ROLLER F	4	O
4	B1749671	IDLE - EXIT ROLLER R	4	O
5	B1749673	PAPER BIN FULL SENSOR	1	O

# 7. FEEDER ROLLER ASSEMBLY

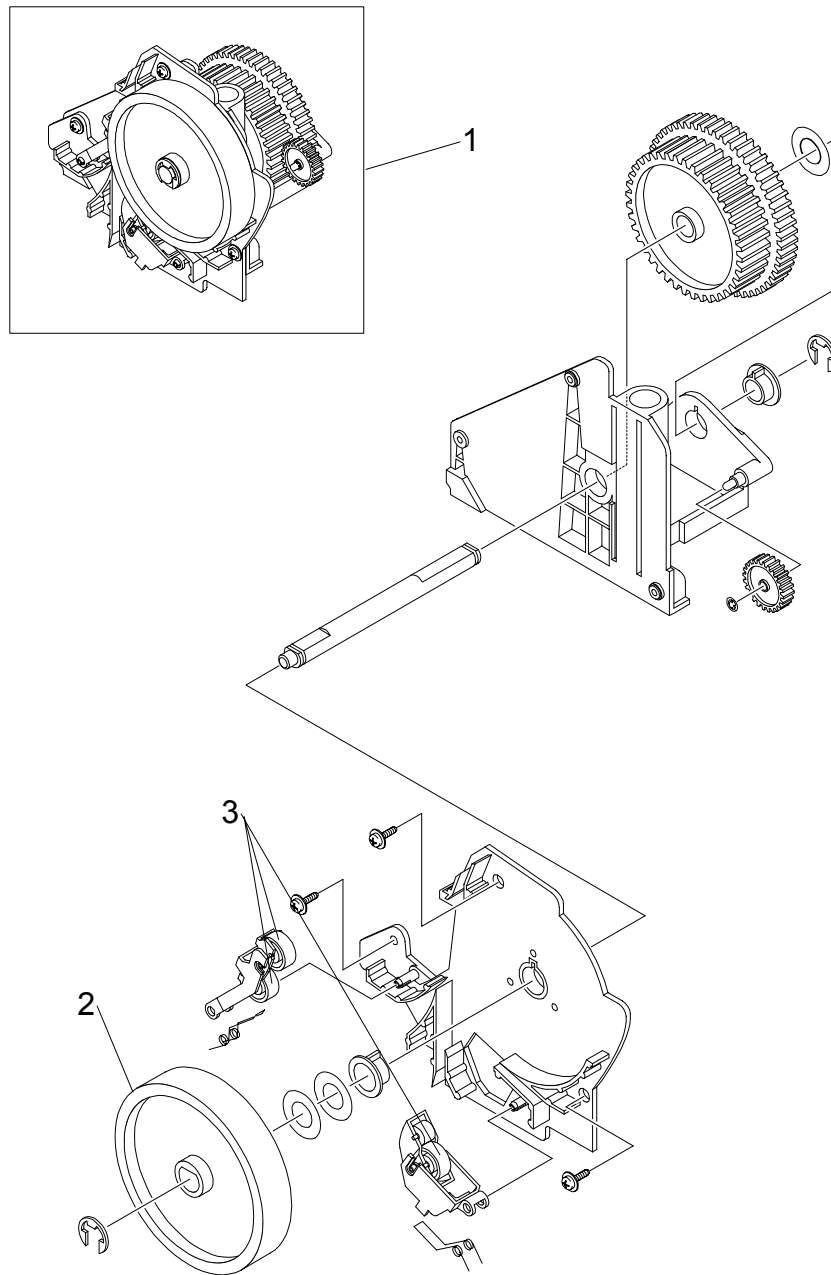

B174C907.WMF

Index No.	Part No.	Description	Q'ty	B174
				17
1	B1749675	PAPER FEED GEAR ASS'Y	1	O
2	B1749676	PAPER FEED ROLLER	1	O
3	B1749677	PAPER FEED ROLLER - IDLE	3	O

## 8. MP ASSEMBLY

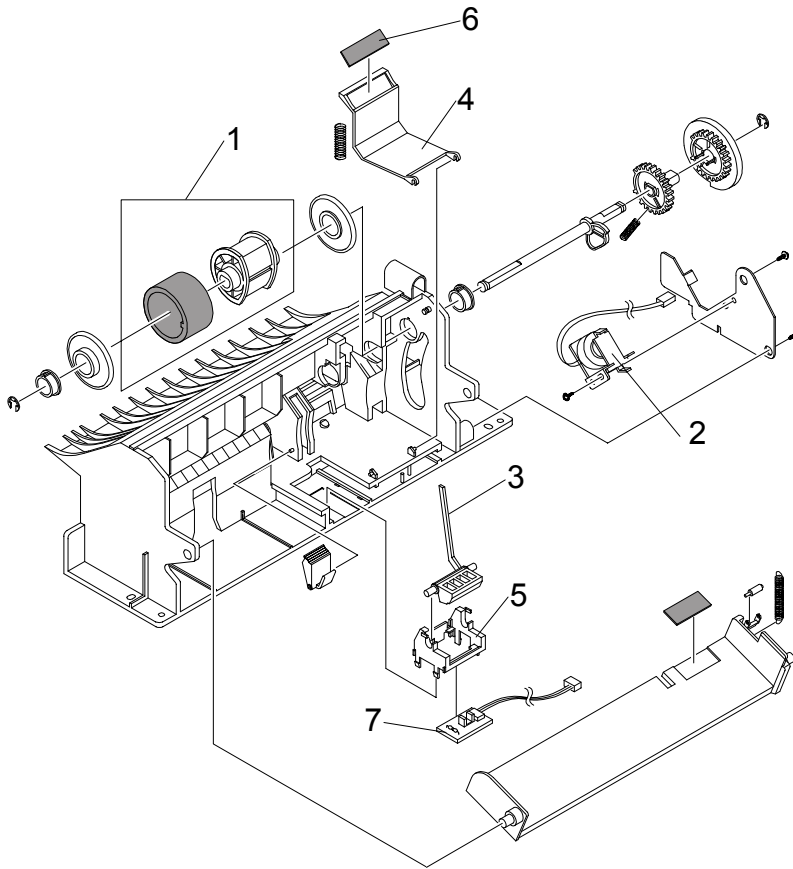
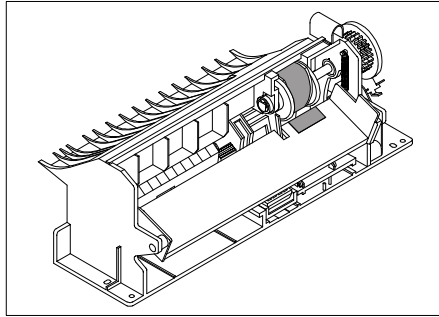

B174C908.WMF

Index No.	Part No.	Description	Q'ty	B174 17
1	B1749678	PAPER PICK-UP ROLLER ASS'Y	1	O
2	B1749681	SOLENOID - PICK-UP	1	O
3	B1749684	ACTUATOR - PAPER PICK-UP	1	O
4	B1749688	HOLDER - FRICTION PAD	1	O
5	B1749689	HOLDER - PICK-UP ACTUATOR	1	O
6	B1749691	FRICTION PAD	1	O
7	B1749693	PAPER PICK-UP SENSOR	1	O

## 9. BASE FRAME ASSEMBLY

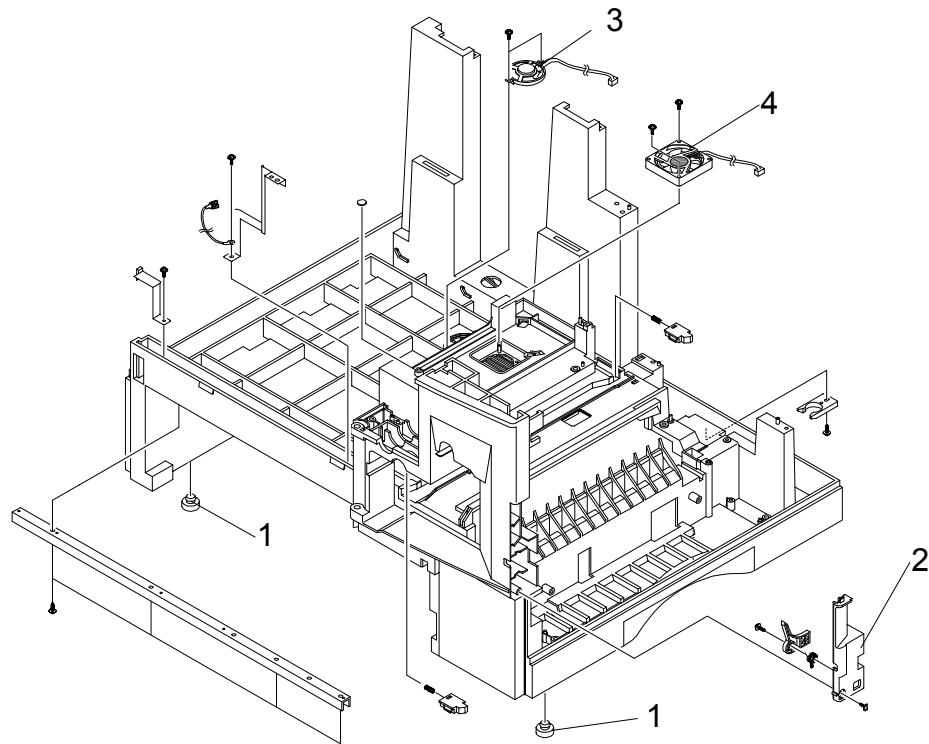
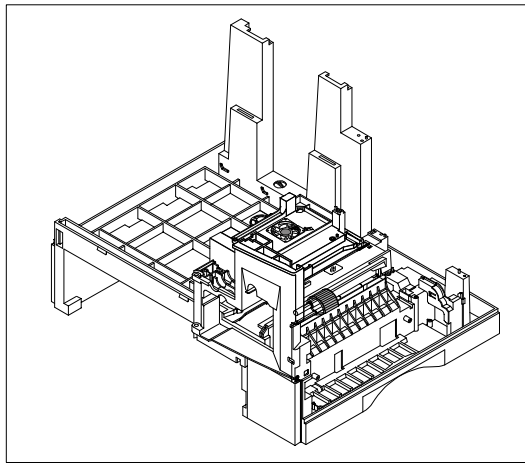

B174C909.WMF

Index No.	Part No.	Description	Q'ty	B174
				17
1	B1749694	RUBBER FOOT - ML80	2	O
2	B1749698	FRONT COVER - DUMMY	1	O
3	B1749699	MONITOR SPEAKER	1	O
4	B1749700	COOLING FAN - LASER UNIT	1	O

# 10. PICK-UP ASSEMBLY

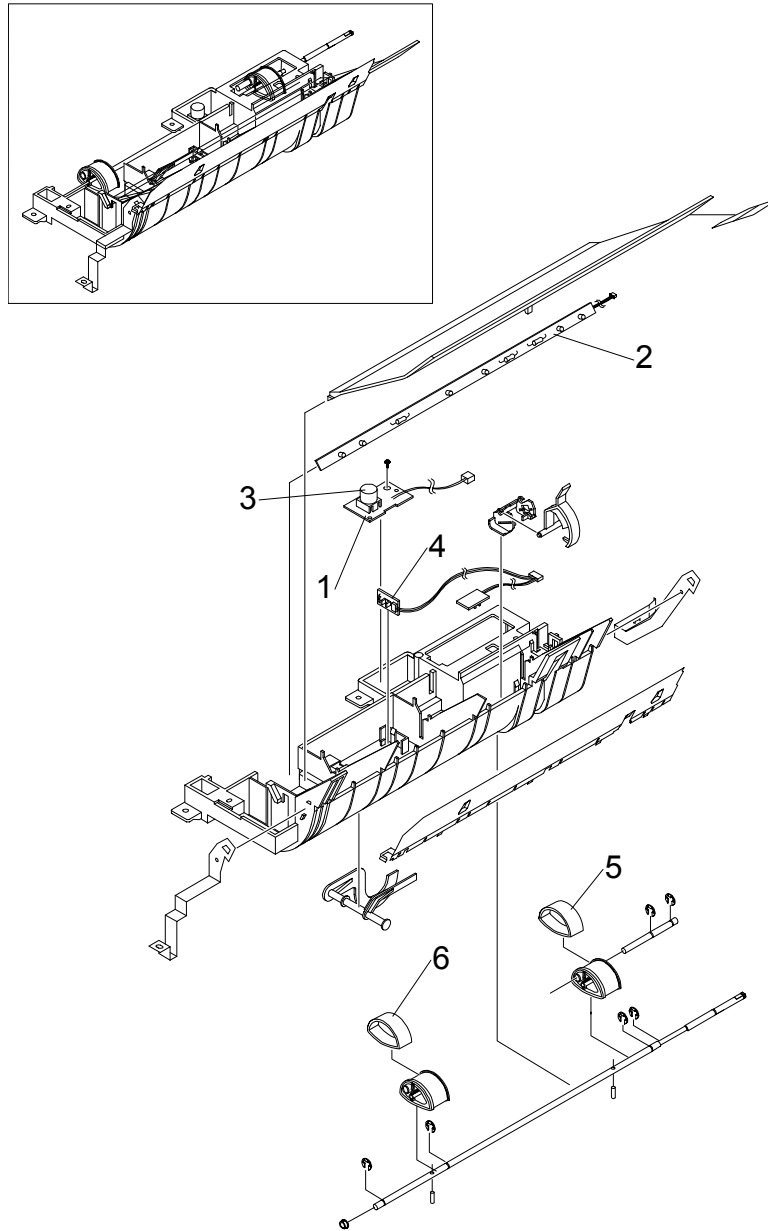

B174C910.WMF

Index No.	Part No.	Description	Q'ty	B174
				17
1	B1749703	TONER SENSOR - TX	1	O
2	B1749704	QUENCHING LAMP	1	O
3	B1749706	LENS - TONER SENSOR	1	O
4	B1749707	PAPER FEED AND END SENSORS	1	O
5	B1749709	RUBBER - PAPER PICK-UP : RIGHT	1	O
6	B1749710	RUBBER - PAPER PICK-UP : LEFT	1	O





# 11. DRIVER ASSEMBLY

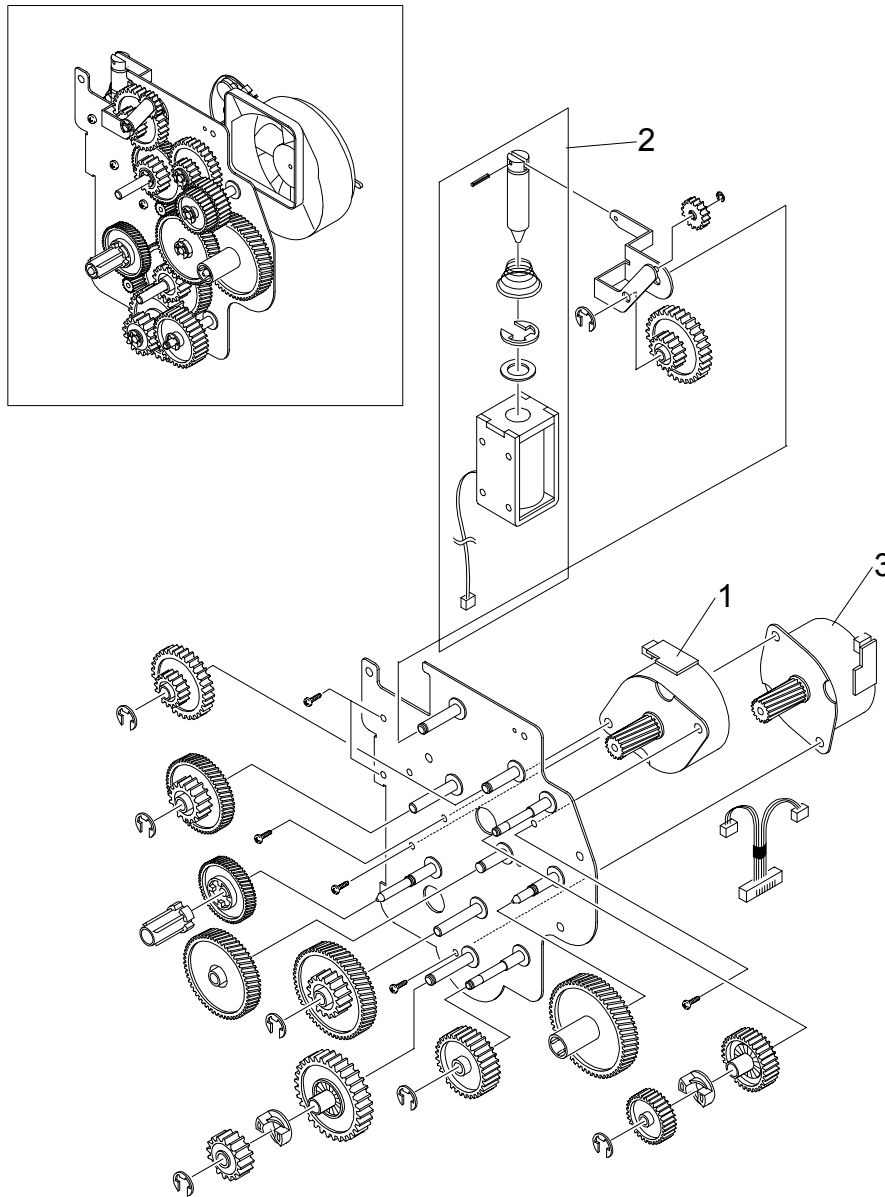

B174C911.WMF

Index No.	Part No.	Description	Q'ty	B174
				17
1	B1749714	STEPPING MOTOR - M49SP-2K	1	O
2	B1749717	SOLENOID - DUPLEX	1	O
3	B1749720	STEPPING MOTOR - M4PSP-2NK	1	O



## 12. MAIN FLAME ASSEMBLY

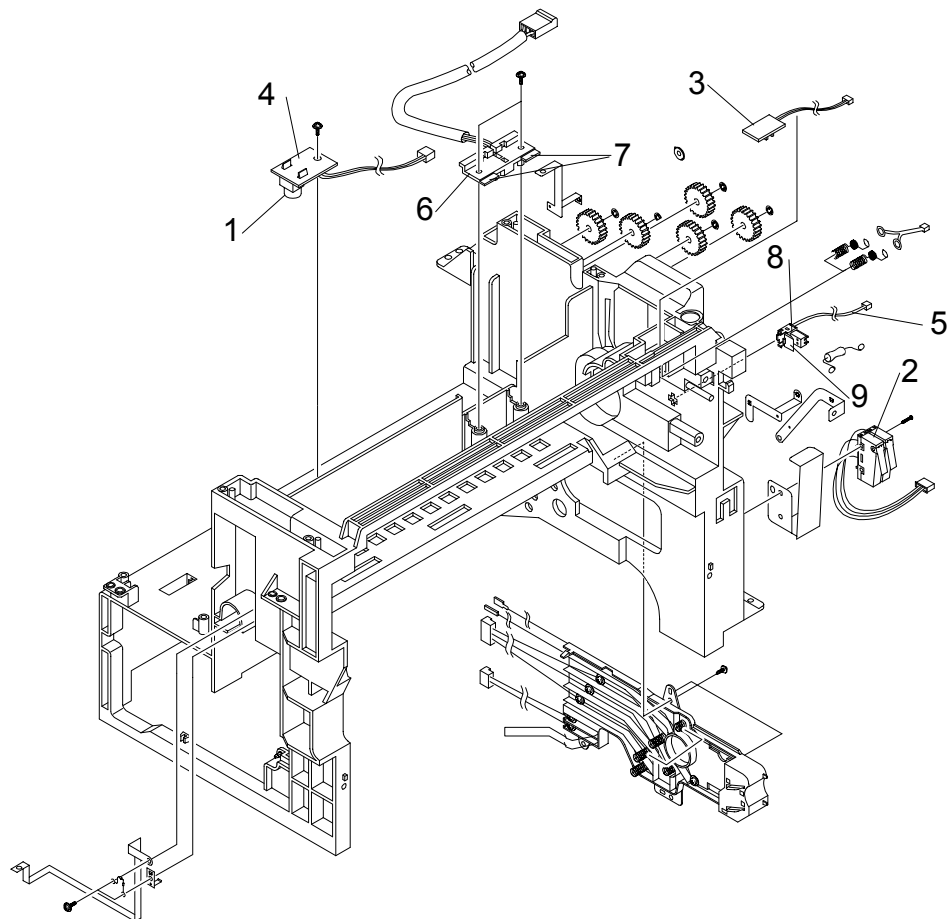
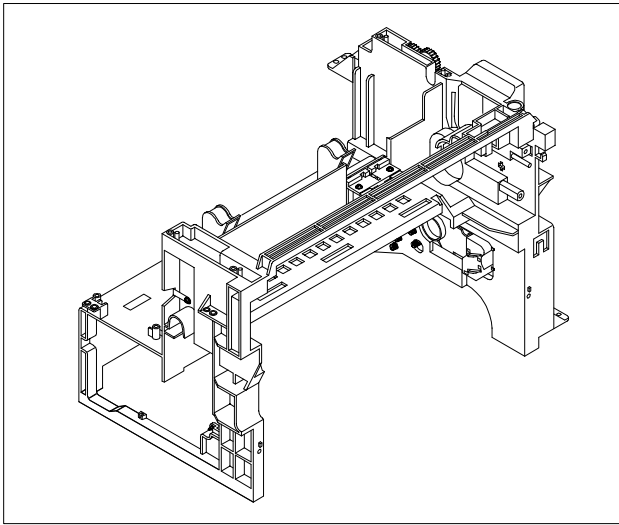

B174C912.WMF

Index No.	Part No.	Description	Q'ty	B174
				17
1	B1749706	LENS - TONER SENSOR	2	O
2	B1749725	MICRO SWITCH	1	O
3	B1749726	EXIT SENSOR	1	O
4	B1749727	TONER SENSOR	1	O
5	B1749730	JOINT HARNESS - THIRMIOTOR	1	O
6	B1749731	TERMINAL HOUSING	1	O
7	B1749732	TERMINAL - FUSING	2	O
8	B1749733	CAP - CONNECTOR L	1	O
9	B1749734	CAP - CONNECTOR U	1	O

# 13. FUSER ASSEMBLY

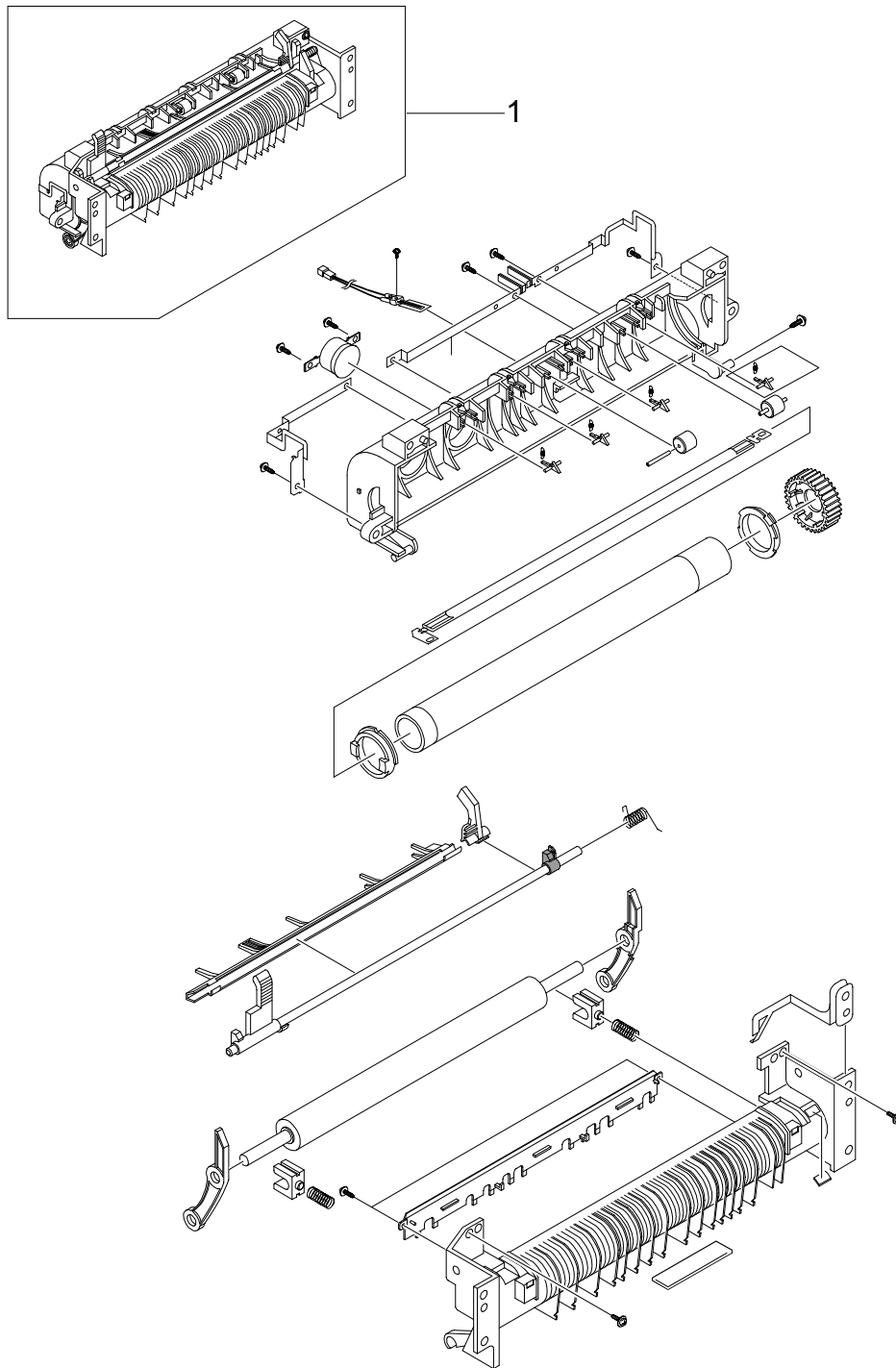

B174C913.WMF

Index No.	Part No.	Description	Q'ty	B174
				17
1	B1749737	FUSING UNIT	1	0

**PARTS CATALOG INDEX**

<b>Part No.</b>	<b>Description</b>	<b>Section and Index No.</b>
B1739583	EXIT ROLLER - PLATEN	3-5
B1739586	PAPER GUIDE - ADF TOP COVER	3-23
B1739601	SENSOR LEVER	2-12
B1739606	SCANNER MOTOR	2-9
B1749500	COPY TARY EXTENTION	1-1
B1749501	COPY TRAY	1-2
B1749502	FRONT COVER	1-3
B1749503	LASER UNIT	1-4
B1749504	PSU - 110V	1-5
B1749505	REAR COVER	1-6
B1749506	PCB - MAIN BOARD	1-7
B1749507	INTERFACE PANEL	1-8
B1749508	COOLING FAN	1-9
B1749511	MAIN SWITCH	1-10
B1749512	PICK-UP SOLENOID	1-11
B1749513	LEFT COVER	1-12
B1749514	CASSETE GUIDE	1-13
B1749515	PCB - NCU : NA	1-14
B1749517	SHIELD PLATE - MAIN	1-15
B1749520	GUIDE - PAPER EXIT	1-16
B1749527	HOLDER ASS'Y - TRANSFER ROLLER : R	1-17
B1749528	HOLDER ASS'Y - TRANSFER ROLLER : L	1-18
B1749529	GEAR - TRANSFER ROLLER	1-22
B1749530	TRANSFER ROLLER	1-23
B1749534	CAM - PAPER EXIT	1-19
B1749535	LOCK LEVER - TONER CARTRIDGE	1-20
B1749536	LEVER - PAPER EXIT	1-21
B1749538	PLATEN COVER ASS'Y - ADF	2-1
B1749539	SCALE - SUB DIRECTION	2-2
B1749540	SCANNER COVER	2-3
B1749541	HOLDER - PLATEN GLASS	2-4
B1749542	PLATEN GLASS	2-5
B1749543	TIMING BELT - SCANNER	2-6
B1749544	SPRING - TIMING BELT	2-7
B1749547	PCB - SCANNER BOARD	2-8
B1749557	CCD HOLDER	2-10
B1749558	SCANNER BASE - OP-PORT	2-11
B1749565	CCD UNIT	2-13
B1749566	FLAT CABLE - CCD	2-14
B1749568	DOCUMENT TABLE	3-1
B1749570	DOCUMENT GUIDE - LEFT	3-2

<b>Part No.</b>	<b>Description</b>	<b>Section and Index No.</b>
B1749571	DOCUMENT GUIDE - RIGHT	3-3
B1749573	HINGE ASS'Y	3-4
B1749577	PLATEN COVER	3-6
B1749578	SPONGE SHEET	3-7
B1749579	WHITE SHEET - ADF	3-8
B1749582	ADF UPPER ASS'Y	3-9
B1749583	ADF RUBBER PAD ASS'Y	3-11
B1749587	DRIVE ROLLER	3-12
B1749589	ACTUATOR - DOCUMENT SENSOR	3-13
B1749590	ACTUATOR - REGIST SENSOR	3-14
B1749591	EXIT ROLLER	3-15
B1749597	WHITE SHEET	3-16
B1749598	PCB - ADF:SUB	3-17
B1749599	REGIST SENSOR	3-18
B1749600	DOCUMENT SENSOR	3-19
B1749604	ADF MAIN CABLE	3-20
B1749605	ADF MOTOR	3-21
B1749606	ADF PICK-UP ASS'Y	3-22
B1749608	ADF TOP COVER	3-24
B1749609	ADF SIDE COVER - LEFT	3-25
B1749610	ADF SIDE COVER - RIGHT	3-26
B1749618	RUBBER - EXIT	4-1
B1749628	BYPASS TRAY ASS'Y	4-2
B1749629	CASE - BYPASS TRAY	4-3
B1749630	EXTENSION - BYPASS TRAY	4-4
B1749631	PAPER GUIDE - BYPASS TRAY	4-5
B1749632	COVER - BYPASS TRAY	4-6
B1749634	TRAY LINK - BYPASS	4-7
B1749637	TIE STRAP	4-8
B1749644	RIGHT COVER	4-9
B1749646	CASSETTE ASS'Y	5-1
B1749647	PAPER FINGER - RIGHT	5-2
B1749655	HANDLE - SIDE FENSE	5-3
B1749660	CASSETTE GRIP	5-4
B1749663	EXIT ROLLER	6-1
B1749664	DECURL - EXIT ROLLER	6-2
B1749670	IDLE - EXIT ROLLER F	6-3
B1749671	IDLE - EXIT ROLLER R	6-4
B1749673	PAPER BIN FULL SENSOR	6-5
B1749675	PAPER FEED GEAR ASS'Y	7-1
B1749676	PAPER FEED ROLLER	7-2
B1749677	PAPER FEED ROLLER - IDLE	7-3

<b>Part No.</b>	<b>Description</b>	<b>Section and Index No.</b>
B1749678	PAPER PICK-UP ROLLER ASS'Y	8-1
B1749681	SOLENOID - PICK-UP	8-2
B1749684	ACTUATOR - PAPER PICK-UP	8-3
B1749688	HOLDER - FRICTION PAD	8-4
B1749689	HOLDER - PICK-UP ACTUATOR	8-5
B1749691	FRICTION PAD	8-6
B1749693	PAPER PICK-UP SENSOR	8-7
B1749694	RUBBER FOOT - ML80	9-1
B1749698	FRONT COVER - DUMMY	9-2
B1749699	MONITOR SPEAKER	9-3
B1749700	COOLING FAN - LASER UNIT	9-4
B1749703	TONER SENSOR - TX	10-1
B1749704	QUENCHING LAMP	10-2
B1749706	LENS - TONER SENSOR	10-3
B1749706	LENS - TONER SENSOR	12-1
B1749707	PAPER FEED AND END SENSORS	10-4
B1749709	RUBBER - PAPER PICK-UP : RIGHT	10-5
B1749710	RUBBER - PAPER PICK-UP : LEFT	10-6
B1749714	STEPPING MOTOR - M49SP-2K	11-1
B1749717	SOLENOID - DUPLEX	11-2
B1749720	STEPPING MOTOR - M4PSP-2NK	11-3
B1749725	MICRO SWITCH	12-2
B1749726	EXIT SENSOR	12-3
B1749727	TONER SENSOR	12-4
B1749730	JOINT HARNESS - THERMISTOR	12-5
B1749731	TERMINAL HOUSING	12-6
B1749732	TERMINAL - FUSING	12-7
B1749733	CAP - CONNECTOR L	12-8
B1749734	CAP - CONNECTOR U	12-9
B1749737	FUSING UNIT	13-1
B1749738	ADF RUBBER KIT	3-10
B1749739	OP-PORT ASS'Y - NA	2-15
B1749740	ONE TOUCH KEY SHEET – ENGLISH – MB001 DELETED	2-15-1
B1749741	ONE TOUCH KEY SHEET - FRENCH	2-16
B1749742	ONE TOUCH KEY SHEET - SPANISH	2-16
B1749743	ONE TOUCH KEY SHEET - PORTUGUESE	2-16
B1749744	ONE TOUCH KEY SHEET – ENGLISH – MB001 ADDED	2-15-1